

DN32 - DN200

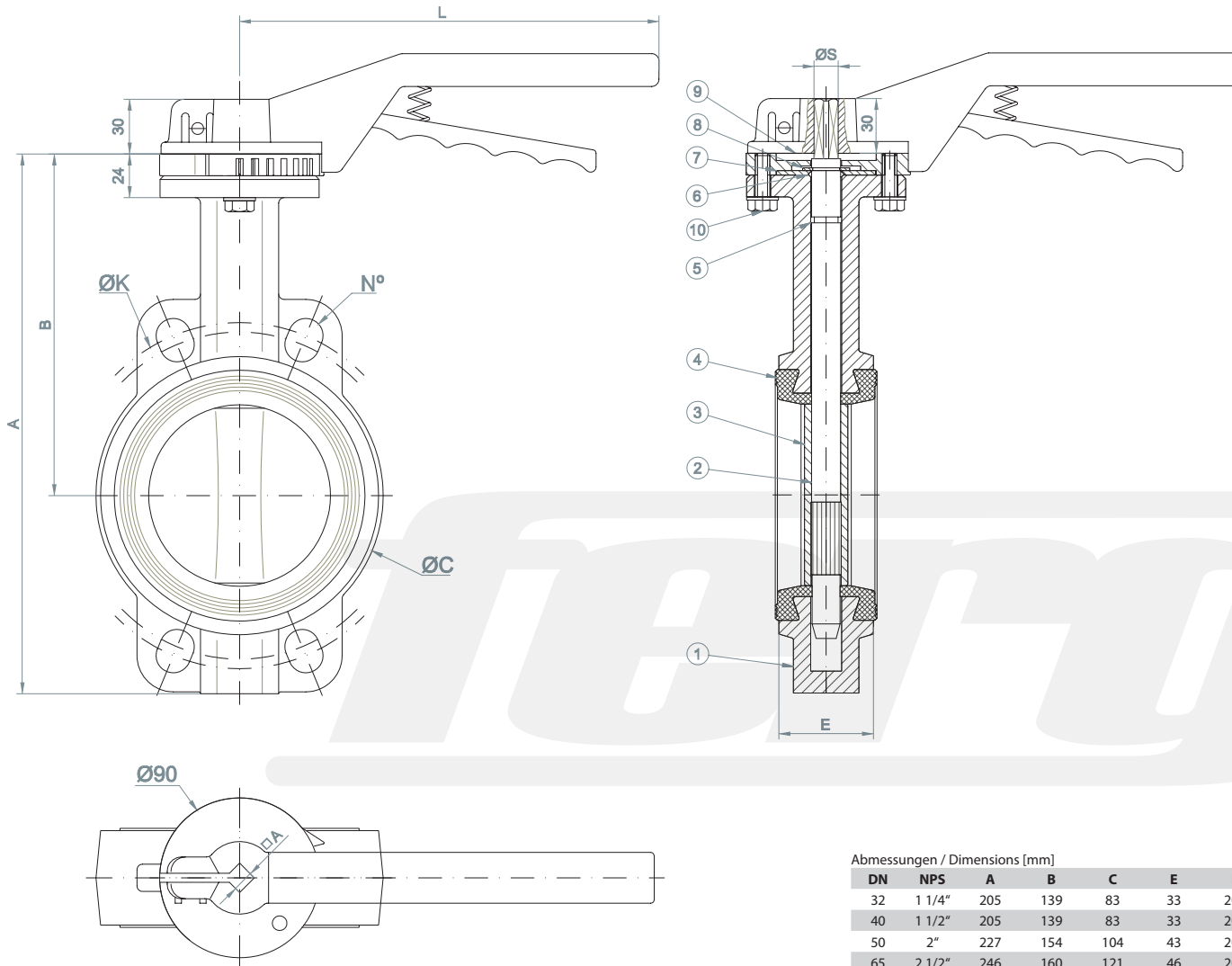

- D**
- Bauform: Zwischenflanschgehäuse
 - Design nach API 609
 - Baulänge nach ISO 5752
 - Kopfflansch nach ISO 5211
 - Flanschanschluss: PN10 / PN16 oder ANSI150
 - Flanschbohrungen: metrisch oder UNC
 - Farbton: RAL 3020, signalrot
 - Mit Handhebel

- E**
- WAFER type
 - Design acc. to API 609
 - face to face acc. to ISO 5752
 - Top flange acc. to ISO 5211
 - Flanges: PN10 / PN16 or ANSI150
 - Drilling holes: metric or UNC
 - Colour: RAL 3020, signal red
 - With hand lever

Werkstoffe / Materials

Item	Bauteil / Part	Material
1	Gehäuse / Body	GJS400 / WCB / AISI 316 / Bronze / Aluminium or other
2	Welle / Shaft	AISI 316 / AISI 420 or other
3	Scheibe / Disc	GJS500 / WCB / AISI316 / Hastelloy C / Alu Bronze or other
4	Sitz / Seat	EPDM / NBR / VITON (FPM) / Silicone / Hypalon or other
5	O-Ring	NBR
6	O-Ring	NBR
7	Unterlegscheibe / Washer	Steel
8	Ringfeder / Circlip	Steel
9	Kopfflansch / Top flange	Aluminium
10	Sechskantschraube / Hex. screw	8.8

Abmessungen / Dimensions [mm]

DN	NPS	A	B	C	E	L	□A	ISO 5211	PN10-ØK	PN10-N°	PN16-ØK	PN16-N°	ANSI150-ØK	ANSI150-N°
32	1 1/4"	205	139	83	33	205	8	F07	100	4	100	4	89	4
40	1 1/2"	205	139	83	33	205	8	F07	110	4	110	4	98,4	4
50	2"	227	154	104	43	205	8	F07	125	4	125	4	120,7	4
65	2 1/2"	246	160	121	46	205	11	F07	145	4	145	4	139,7	4
80	3"	260	170	132	46	205	11	F07	160	4	160	4	152,4	4
100	4"	295	187	154	52	205	11	F07	180	4	180	4	190,5	4
125	5"	324	205	189	56	250	14	F07	210	4	210	4	215,9	4
150	6"	349	217	218	56	400	14	F07	240	4	240	4	241,3	4
200	8"	442	257	269	60	400	17	F07	295	4	295	4	298,5	4

DN250 - DN300

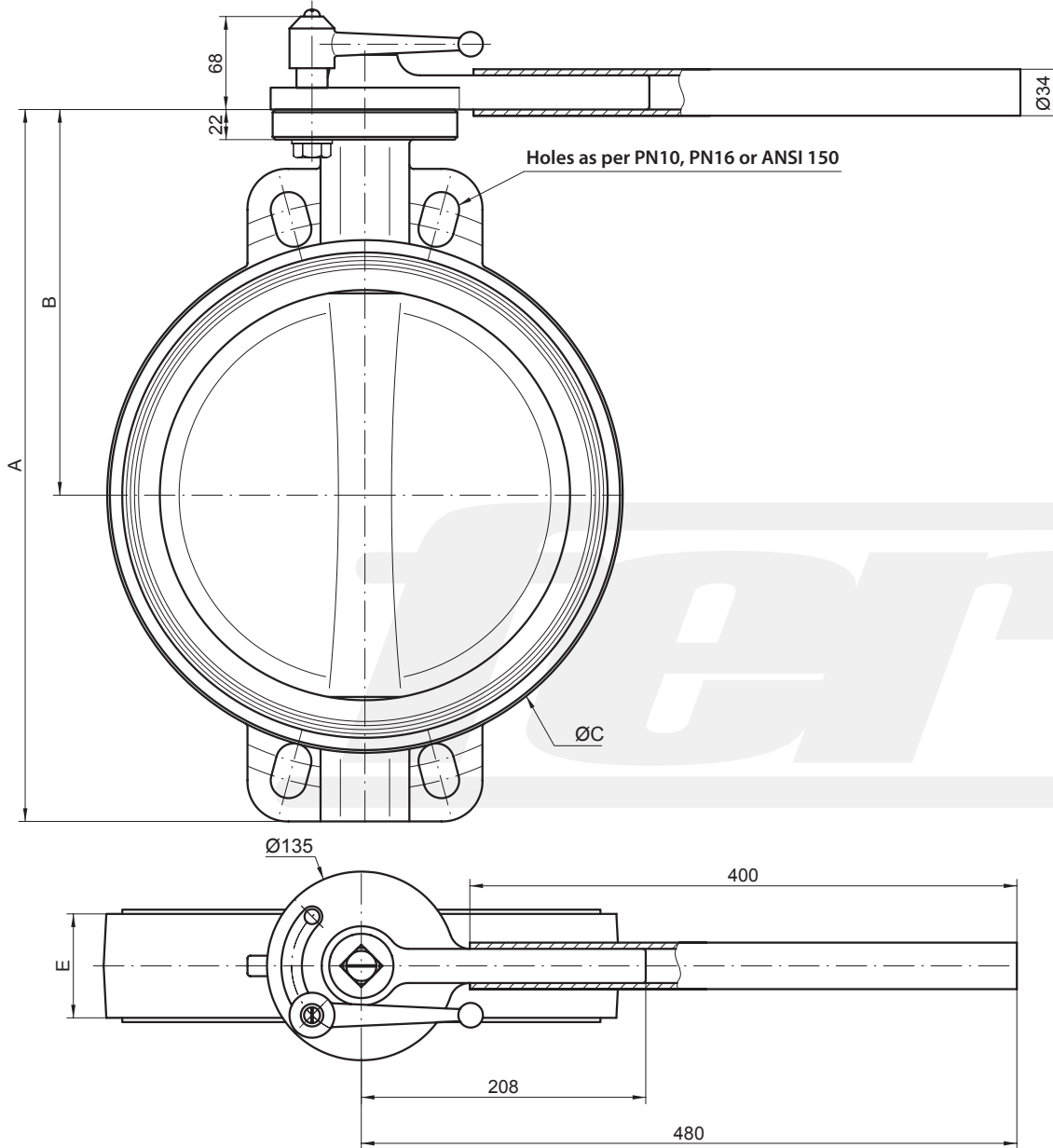

- D**
- Bauform: Zwischenflanschgehäuse
 - Design nach API 609
 - Baulänge nach ISO 5752
 - Kopfflansch nach ISO 5211
 - Flanschanschluss: PN10 / PN16 oder ANSI150
 - Flanschbohrungen: metrisch oder UNC
 - Farbton: RAL 3020, signalrot
 - Mit Feinregulier-Handhebel

- E**
- WAFER type
 - Design acc. to API 609
 - face to face acc. to ISO 5752
 - Top flange acc. to ISO 5211
 - Flanges: PN10 / PN16 or ANSI150
 - Drilling holes: metric or UNC
 - Colour: RAL 3020, signal red
 - With multiposition lever

Werkstoffe / Materials

Item	Bauteil / Part	Material
1	Gehäuse / Body	GJS400 / WCB / AISI 316 / Bronze / Aluminium or other
2	Welle / Shaft	AISI 316 / AISI 420 or other
3	Scheibe / Disc	GJS500 / WCB / AISI316 / Hastelloy C / Alu Bronze or other
4	Sitz / Seat	EPDM / NBR / VITON (FPM) / Silicone / Hypalon or other
5	O-Ring	NBR
6	O-Ring	NBR
7	Unterlegscheibe / Washer	Steel
8	Ringfeder / Circlip	Steel
9	Kopfflansch / Top flange	Aluminium
10	Sechskantschraube / Hex. screw	8.8

Abmessungen / Dimensions [mm]

DN	NPS	A	B	C	E
250	10"	452	255	327	68
300	12"	522	288	377	78

AK110 - MULTIPOS. LEVER

copyright © by
FERGO® Armaturen GmbH

Blindeisenweg 31
D-41468 Neuss

Tel.: +49(0) 2131 - 15 39 28-0
Fax: +49(0) 2131 - 15 39 28-99

Web: www.fergo.biz
E-Mail: info@fergo.biz

fergo®

SEATS / SITZDICHTUNGEN

Material	ISO 1629	Chemical name	Utilities	Temperature
EPDM			Water, sea water, weak, mineral, alcohols, ketones	-20 ... 100°C
EPDM ... B				
EPDM ... HT	EPDM	Ethylene Propylene Terpolymer	High temperature	-20 ... 130°C
EPDM ... KP			KTW Approval	-20 ... 130°C
NORDEL			Abrasion resistance	-20 ... 95°C
NATURAL				
NATURAL ... B	NR	1,4 cis Polisoprene	Very good abrasion resistance	-15 ... 70°C
NEOPRENE				
NEOPRENE ... B	CR	Polychloroprene	Moderate resistance to oil and greases	-25 ... 80°C
BUTYL	IIR	Isobutylene-Isoprene	Permeability inert gas	-10 ... 95°C
NITRILE			Oil, greases, gas oil, H ₂	
NITRILE CARBOX.	NBR ... X	Acrylonitrile-butadiene copolymer	Furthermore abrasion resistance	-10 ... 100°C
NITRILE ... B (white)	NBR	Acrylonitrile-butadiene copolymer	FDA (Food) 21 CFR 177.2600	-10 ... 120°C
HYPALON	CSM	Chlorosulfonated polyethylene	Moderate resistance to oil and greases	-20 ... 125°C
ECO	ECO	Epiclorhydrin ethylen oxide copolymer	Brine, refrigerant fluid	-40 ... 125°C
SILICONE				
FOOD SILICONE	MVQ	Poly (methyl-vinyl) siloxane	Highest and lowest temperature resistance	-60 ... 180°C
STEAM SILICONE			Steam water	-60 ... 140°C
FLUORSILICONE	FMVQ	Poly (fluor methyl-vinyl) siloxane	Oil, greases	-60 ... 180°C
VITON				
VITON ... B	FPM	Hexafluorpropylene vinylidene copolymer	Best chemical resistance	-15 ... 190°C
VITON ... GF		HPF-VDF-TFE-CSM Tetrapolymer	Oxygenated gasolines	-15 ... 190°C
FLUCAST AB/P	*	*	Excellent abrasion resistance	-25 ... 75°C
FLUCAST AF100	*	*	Excellent resistance to strong acids and basis	0 ... 180°C

KURVENDIAGRAMM / FLOW CURVE DIAGRAM

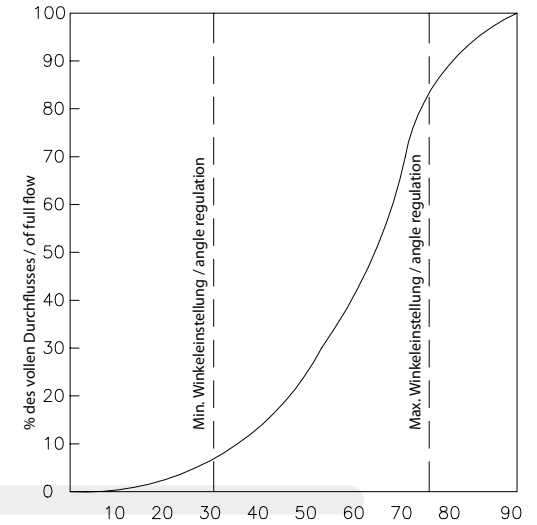

DRUCKVERLUSTDIAGRAMM / PRESSURE LOSS DIAGRAM

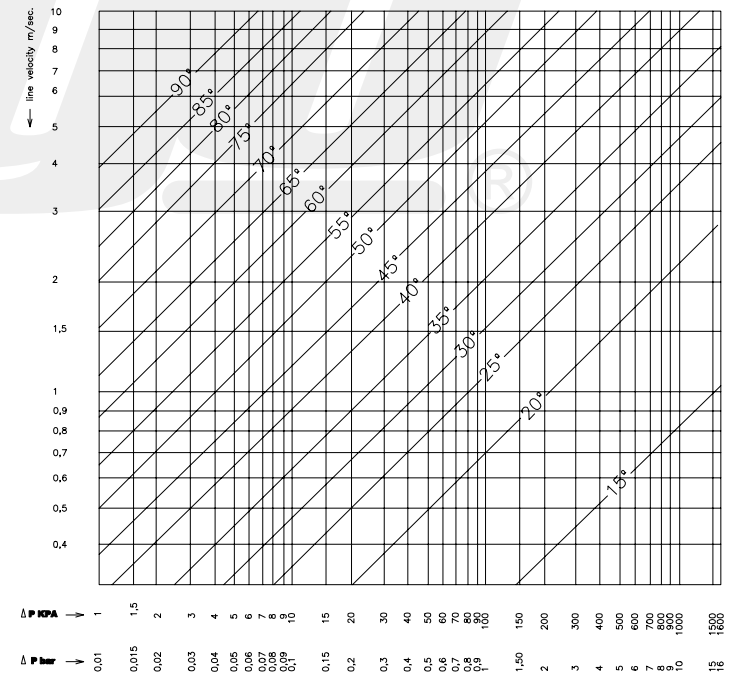

DURCHFLUSSDIAGRAMM / FLOW CHART

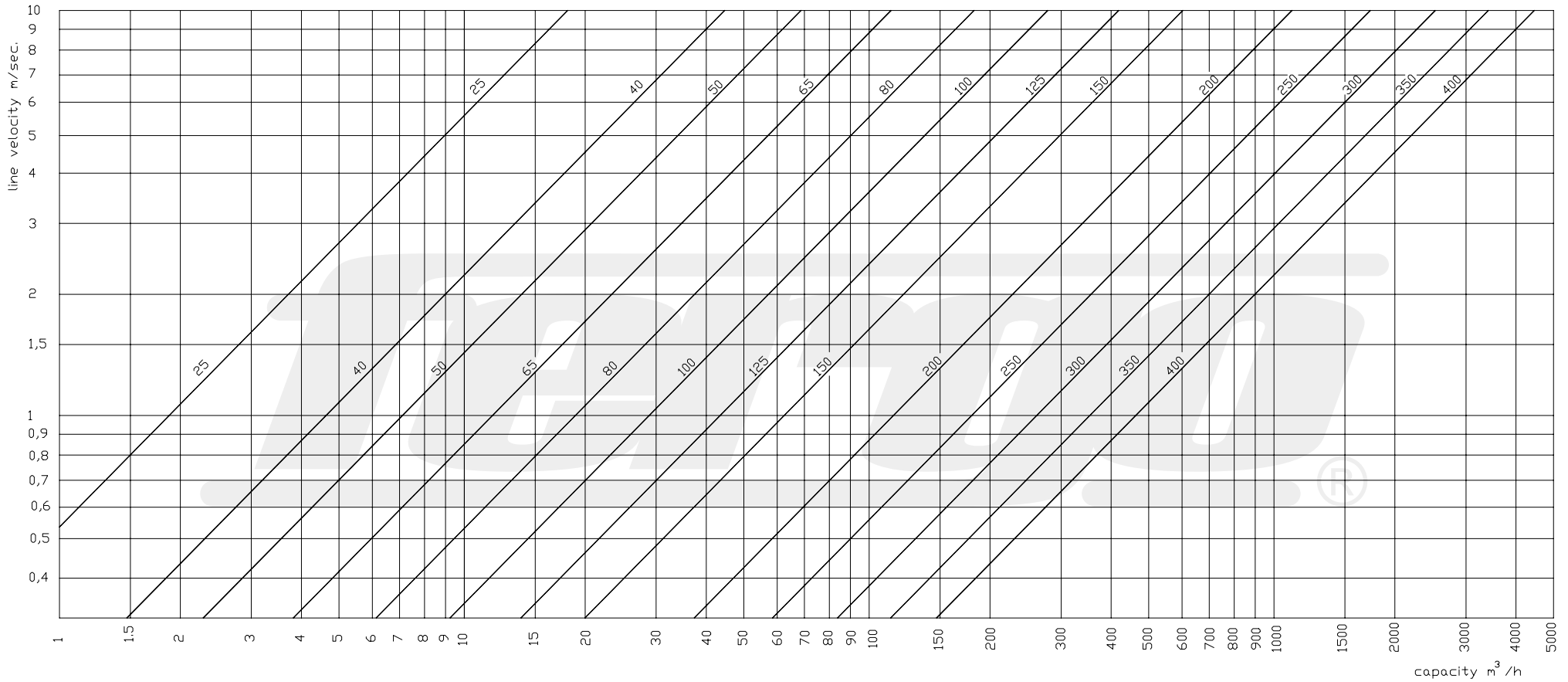

Design and materials can be changed without notice. Errors and omissions excepted

ANSCHLUSSMAßE / CONNECTIONS PN10

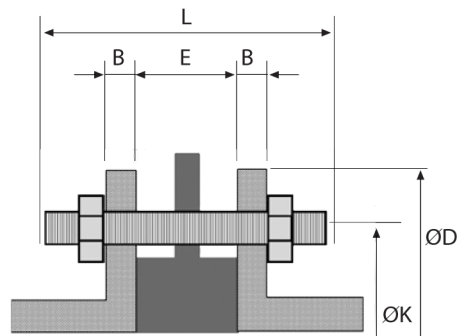

AK110

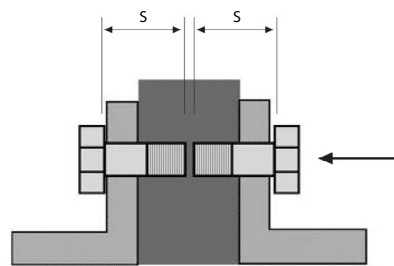

AK110 ≥ DN450

Schrauben
Screws

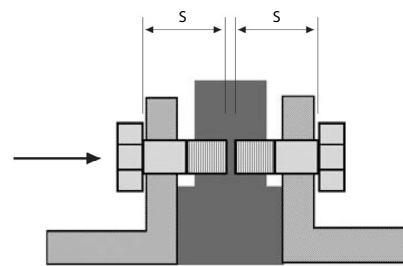

AK111

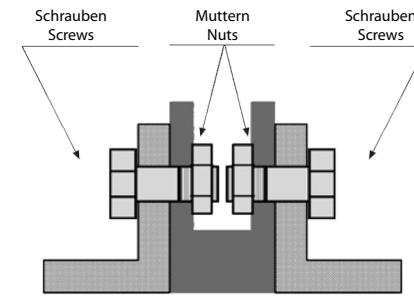

AK113

Armatur / Valve		AK110 - Zwischenflanschführung / Wafer Type									AK111 - Anflanschführung / Lug Type			AK113 - Flanschführung / Flanged Type (DIN 2632)			
		Gewindestange / Threaded rod			Nuts / Muttern			Schrauben / Screws			Schrauben / Screws			Dicke Thickness	Lochkreis Centers	Bohrungen Holes	Extern External
DN	Breite Width	Länge Lengh	Gewinde Thread	Menge Quantity	Gewinde Thread	Menge Quantity	Länge Lengh	Gewinde Thread	Menge Quantity	Länge Lengh	Gewinde Thread	Menge Quantity	B				
32	1 1/4"	33	M16	4	M16	8	--	--	--	30	M16	8	16	100	4	140	
40	1 1/2"	33	M16	4	M16	8	--	--	--	30	M16	8	16	110	4	150	
50	2"	43	M16	4	M16	8	--	--	--	35	M16	8	18	125	4	165	
65	2 1/2"	46	M16	4	M16	8	--	--	--	35	M16	8	18	145	4	185	
80	3"	46	M16	8	M16	16	--	--	--	40	M16	16	20	160	8	200	
100	4"	52	M16	8	M16	16	--	--	--	40	M16	16	20	180	8	220	
125	5"	56	M16	8	M16	16	--	--	--	45	M16	16	22	210	8	250	
150	6"	56	M20	8	M20	16	--	--	--	45	M20	16	22	240	8	285	
200	8"	60	M20	8	M20	16	--	--	--	50	M20	16	24	295	8	340	
250	10"	68	M20	12	M20	24	--	--	--	55	M20	24	26	350	12	395	
300	12"	78	M20	12	M20	24	--	--	--	60	M20	24	26	400	12	445	
350	14"	78	M20	16	M20	32	--	--	--	60	M20	32	26	460	16	505	
400	16"	102	M24	16	M24	32	--	--	--	70	M24	32	26	515	16	565	
450	18"	114	M24	16	M24	32	80	M24	8	80	M24	40	28	565	20	615	
500	20"	127	M24	16	M24	32	80	M24	8	85	M24	40	28	620	20	670	
600	24"	154	M27	16	M27	32	90	M27	8	--	--	--	28	725	20	780	
700	28"	165	M27	20	M27	40	100	M27	8	--	--	--	30	840	24	895	
800	32"	190	M30	20	M30	40	110	M30	8	--	--	--	32	950	24	1015	
900	36"	203	M30	24	M30	48	120	M30	8	--	--	--	34	1050	28	1115	
1000	40"	216	M33	24	M33	48	130	M33	8	--	--	--	34	1160	28	1230	
1200	48"	254	M36	28	M36	56	150	M36	8	--	--	--	38	1380	32	1455	

Design and materials can be changed without notice. Errors and omissions excepted

ANSCHLUSSMAßE / CONNECTIONS PN16

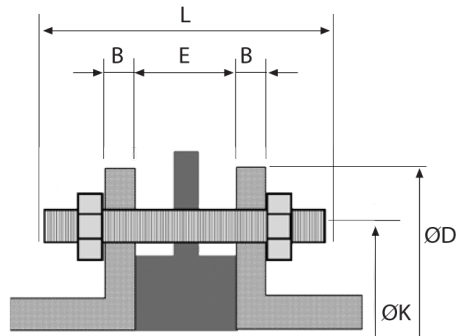

AK110

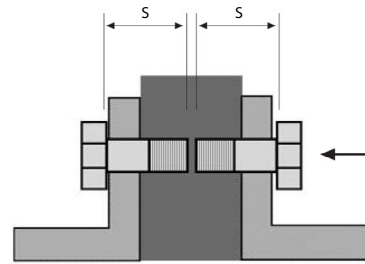

AK110 ≥ DN450

Schrauben
Screws

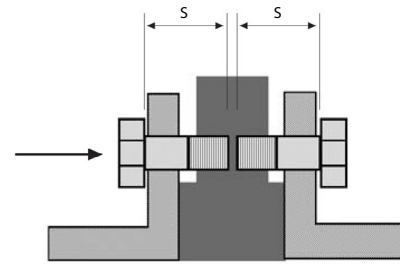

AK111

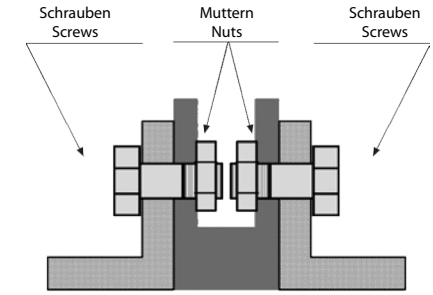

AK113

Armatur / Valve		AK110 - Zwischenflanschführung / Wafer Type									AK111 - Anflanschführung / Lug Type			AK113 - Flanschführung / Flanged Type (DIN 2632)			
		Gewindestange / Threaded rod			Nuts / Muttern			Schrauben / Screws			Schrauben / Screws			Dicke Thickness	Lochkreis Centers	Bohrungen Holes	Extern External
DN	Breite Width	Länge Lengh	Gewinde Thread	Menge Quantity	Gewinde Thread	Menge Quantity	Länge Lengh	Gewinde Thread	Menge Quantity	Länge Lengh	Gewinde Thread	Menge Quantity	B				
32	1 1/4"	33	110	M16	4	M16	8	--	--	30	M16	8	16	100	4	140	
40	1 1/2"	33	110	M16	4	M16	8	--	--	30	M16	8	16	110	4	150	
50	2"	43	120	M16	4	M16	8	--	--	35	M16	8	18	125	4	165	
65	2 1/2"	46	125	M16	4	M16	8	--	--	35	M16	8	18	145	4	185	
80	3"	46	130	M16	8	M16	16	--	--	40	M16	16	20	160	8	200	
100	4"	52	135	M16	8	M16	16	--	--	40	M16	16	20	180	8	220	
125	5"	56	140	M16	8	M16	16	--	--	45	M16	16	22	210	8	250	
150	6"	56	150	M20	8	M20	16	--	--	45	M20	16	22	240	8	285	
200	8"	60	160	M20	12	M20	16	--	--	50	M20	24	24	295	12	340	
250	10"	68	180	M24	12	M24	24	--	--	55	M24	24	26	355	12	405	
300	12"	78	195	M24	12	M24	24	--	--	65	M24	24	28	410	12	460	
350	14"	78	195	M24	16	M24	32	--	--	65	M24	32	30	470	16	520	
400	16"	102	235	M27	16	M27	32	--	--	80	M27	32	32	525	16	580	
450	18"	114	250	M27	16	M27	32	80	M27	8	85	M27	40	585	20	640	
500	20"	127	270	M30	16	M30	32	80	M30	8	95	M30	40	650	20	715	
600	24"	154	300	M33	16	M33	32	90	M33	8	--	--	36	770	20	840	
700	28"	165	325	M33	20	M33	40	100	M33	8	--	--	36	840	24	910	
800	32"	190	355	M36	20	M36	40	110	M36	8	--	--	38	950	24	1025	
900	36"	203	372	M36	24	M36	48	120	M36	8	--	--	40	1050	28	1125	
1000	40"	216	396	M39	24	M39	48	130	M39	8	--	--	42	1170	28	1255	
1200	48"	254	459	M45	28	M45	56	160	M39	8	--	--	48	1390	32	1485	

Design and materials can be changed without notice. Errors and omissions excepted

ANSCHLUSSMAßE / CONNECTIONS ANSI 150 LBS

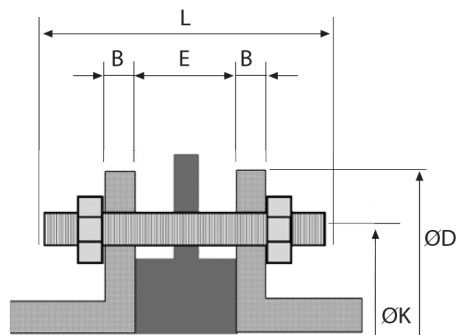

AK110

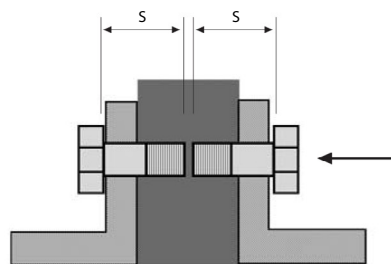

AK110 ≥ DN450

Schrauben
Screws

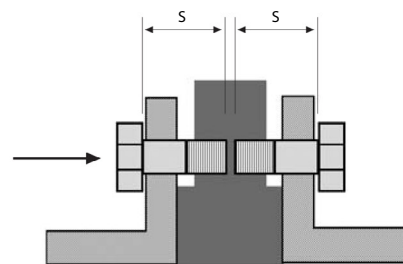

AK111

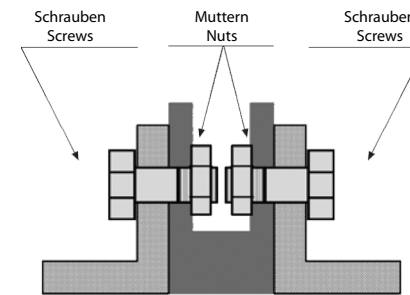

AK113

Armatur / Valve		AK110 - Zwischenflanschführung / Wafer Type									AK111 - Anflanschführung / Lug Type			AK113 - Flanschführung / Flanged Type (DIN 2632)			
		Gewindestange / Threaded rod			Nuts / Muttern			Schrauben / Screws			Schrauben / Screws			Dicke Thickness	Lochkreis Centers	Bohrungen Holes	Extern External
DN	Breite Width	Länge Lengh	Gewinde Thread	Menge Quantity	Gewinde Thread	Menge Quantity	Länge Lengh	Gewinde Thread	Menge Quantity	Länge Lengh	Gewinde Thread	Menge Quantity	B				
32	1 1/4"	33	110	5/8"	4	5/8"	8	--	--	--	30	5/8"	8	15,9	88,9	4	117,5
40	1 1/2"	33	110	5/8"	4	5/8"	8	--	--	--	30	5/8"	8	17,5	98,4	4	127,0
50	2"	43	120	5/8"	4	5/8"	8	--	--	--	35	5/8"	8	19,1	120,6	4	152,4
65	2 1/2"	46	130	5/8"	4	5/8"	8	--	--	--	40	5/8"	8	22,2	139,7	4	177,8
80	3"	46	135	5/8"	8	5/8"	16	--	--	--	40	5/8"	16	23,8	152,4	4	190,5
100	4"	52	140	5/8"	8	5/8"	16	--	--	--	45	5/8"	16	23,8	190,5	8	228,6
125	5"	56	155	3/4"	8	3/4"	16	--	--	--	45	3/4"	16	23,8	215,9	8	254,0
150	6"	56	155	3/4"	8	3/4"	16	--	--	--	45	3/4"	16	25,4	241,3	8	279,4
200	8"	60	165	3/4"	8	3/4"	16	--	--	--	50	3/4"	16	28,6	298,4	8	342,9
250	10"	68	185	7/8"	12	7/8"	24	--	--	--	60	7/8"	24	30,2	361,9	12	406,4
300	12"	78	200	7/8"	12	7/8"	24	--	--	--	65	7/8"	24	31,8	431,8	12	482,6
350	14"	78	215	1"	12	1"	24	--	--	--	70	1"	24	34,9	476,2	12	533,4
400	16"	102	245	1"	16	1"	32	--	--	--	85	1"	32	36,5	539,7	16	596,9
450	18"	114	265	1 1/8"	16	1 1/8"	32	70	1 1/8"	8	90	1 1/8"	32	39,7	577,8	16	635,0
500	20"	127	285	1 1/8"	16	1 1/8"	32	75	1 1/8"	8	100	1 1/8"	40	42,9	635,0	20	698,5
600	24"	154	305	1 1/4"	16	1 1/4"	32	75	1 1/4"	8	--	--	--	47,6	749,3	20	812,8

Design and materials can be changed without notice. Errors and omissions excepted

EXPLOSIONSZEICHNUNG / EXPLODED ASSEMBLY

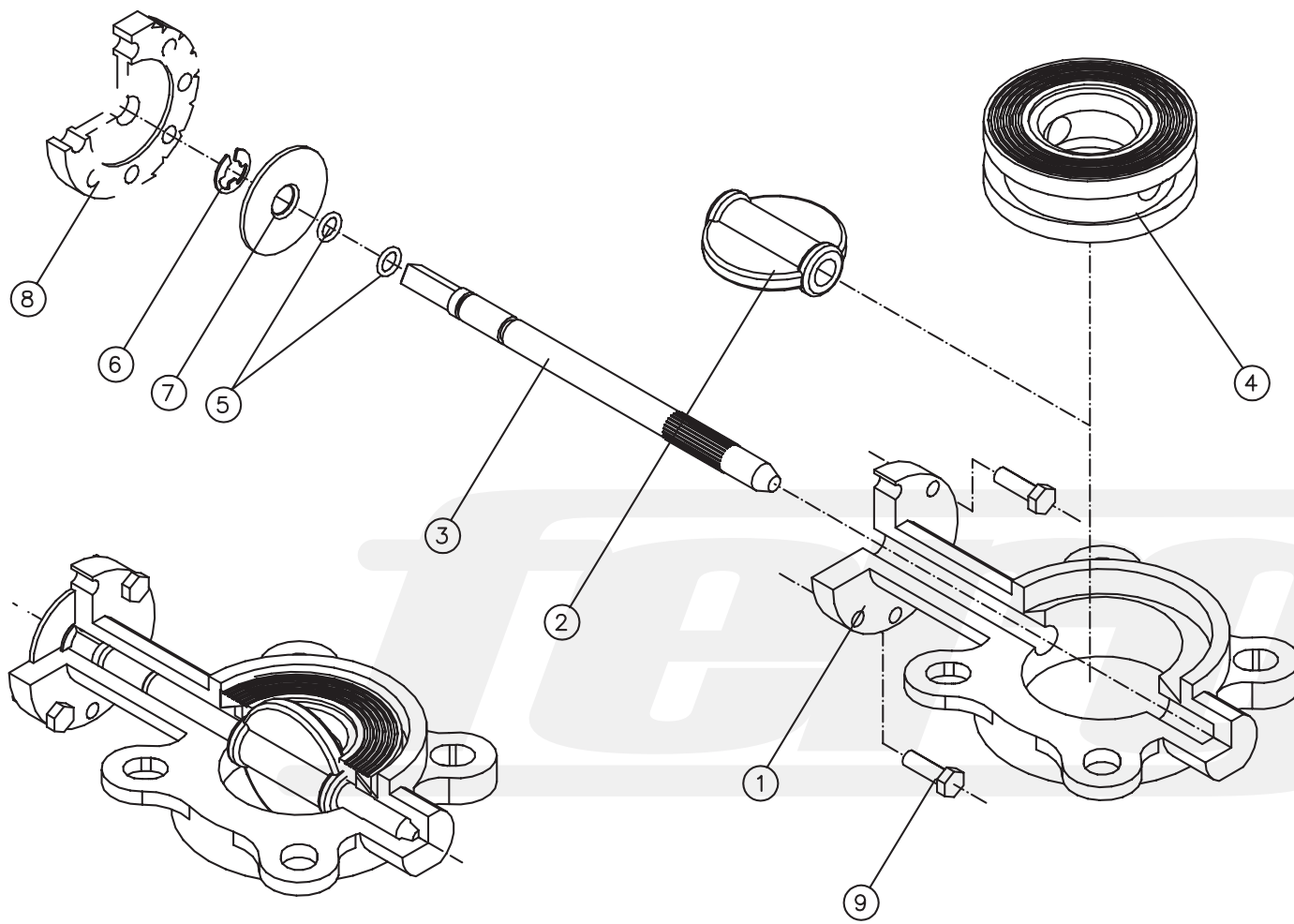

Demontage / Disassembly

- D**
1. Sechskantschrauben lösen (N°9)
 2. Abdeckplatte abnehmen (N°8)
 3. Welle herausziehen (N°3)
 4. Scheibe entnehmen (N°2)
 5. Sitz herausnehmen (N°4)

- E**
1. To unscrew the subject's screws (N°9)
 2. To take out the cover (N°8)
 3. To remove the central shaft (N°3)
 4. To take out the disk (N°2)
 5. To remove the seat of the body (N°4)

Montage / Assembly

- D**
1. Sitz einbauen (N°4)
 2. Scheibe einbauen (N°2)
 3. Welle einsetzen (N°3)
 4. Abdeckplatte aufsetzen (N°8)
 5. Sechskantschrauben anziehen (N°9)

- E**
1. To assemble the seat in the body (N°4)
 2. To assemble the disk (N°2)
 3. To insert the central shaft (N°3)
 4. To assemble the cover (N°8)
 5. To screw the subject's screws (N°9)

Werkstoffe / Materials

Nr. Bauteil / Part

- | | |
|---|--------------------------------|
| 1 | ISO-Flansch / Top flange |
| 2 | Scheibe / Disc |
| 3 | Welle / Shaft |
| 4 | Sitz / Seat |
| 5 | O-Ringe / O-rings |
| 6 | Ringfeder / Circlip |
| 7 | Unterlegscheibe / Washer |
| 8 | Abdeckplatte / Cover |
| 9 | Sechskantschraube / Hex. screw |

AK110/111/113

copyright © by
FERGO® Armaturen GmbH

Blindeisenweg 31
D-41468 Neuss

Tel.: +49(0)2131 - 15 39 28-0
Fax: +49(0)2131 - 15 39 28-99

Web: www.fergo.biz
E-Mail: info@fergo.biz

fergo®