

## Steam Trap BK 27N PN 40 and 63, DN 50 (40) 2" (1½")

### Description

Thermostatic steam trap with corrosion-resistant thermostatic element (Duo stainless steel bimetallic regulator, externally adjustable) unaffected by waterhammer. With internal Y-type strainer, integrated non-return valve and asbestos-free cover gasket (graphite). Installation in any position.

The default factory setting allows the steam trap to discharge condensate with virtually no banking-up. For more undercooling the settings of the installed, depressurized steam trap can be modified externally.

### Function

During start-up of the plant the Duo stainless steel plates are flat. The service pressure acts in the opening direction, the valve is completely open. As the condensate temperature rises, the plates deflect, drawing the stage nozzle towards the closed position. As the condensate temperature sinks, the deflection of the Duo stainless steel plates decreases and the steam trap opens at the adjusted opening temperature.

The thermostatic and spring characteristics of the stack of plates are balanced such that condensate is always discharged at a given undercooling temperature.

The trap provides automatic air-venting at start-up and during operation. BK 27N can also be used for thermal air-venting in steam systems.

### Technical Data

Pressure / Temperature Ratings		PN 40				
Material		16Mo3 (1.5415)				
End connection		Flanges DIN EN, PN 40				
Max. service pressure	PMA [bar]	40.0	38.2	30.2	26.7	25.8
Related temperature	TMA [°C]	20	200	300	400	450
Max differential pressure (inlet pressure minus outlet pressure)	D PMX [bar]	40				

Pressure / Temperature Ratings		PN 63				
Material		16Mo3 (1.5415)				
End connection		Flanges DIN EN, PN 63; ASME Class 400 RF				
Max. service pressure	PMA [bar]	63.0	60.2	47.6	42.0	40.6
Related temperature	TMA [°C]	20	200	300	400	450
Max differential pressure (inlet pressure minus outlet pressure)	D PMX [bar]	45				

Materials	EN	ASTM <sup>1)</sup>
Body	16Mo3 (1.5415)	A 182 F1
Cover	16Mo3 (1.5415)	A 182 F1
Bolts	21CrMoV5-7 (1.7709)	
Nuts	21CrMoV5-7 (1.7709)	
Plug	21CrMoV5-7 (1.7709)	
Bimetallic regulator	Stainless steel	
Other internals	Stainless steel	
Gasket for plug	1.4301	
Gasket for body	Graphite / CrNi	

<sup>1)</sup> Physical and chemical properties comply with EN grade. ASTM nearest equivalent is stated for guidance only.

Dimensions and weights		Flanged to DIN EN PN 40		Flanged to DIN EN PN 63		Flanged to ASME Class 400 RF	
Nominal size DN	[mm]	40	50	40	50	40	50
Nominal size DN	[inch]	1½	2	1½	2	1½	2
Overall length L	[mm]	230	230	260	300	241	292
Approx. weight	[kg]	14.7	14.7	17.5	18.5	20	21

Dimensions and weights		Socket-weld ends		Butt-weld ends	
Nominal size DN	[mm]	40	50	40	50
Nominal size DN	[inch]	1½	2	1½	2
Overall length L	[mm]	180	260 <sup>2)</sup>	180	180
Approx. weight	[kg]	9	9	9	9

<sup>2)</sup> with buttering ends

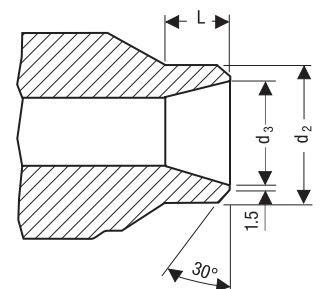
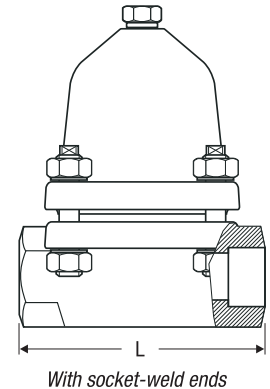
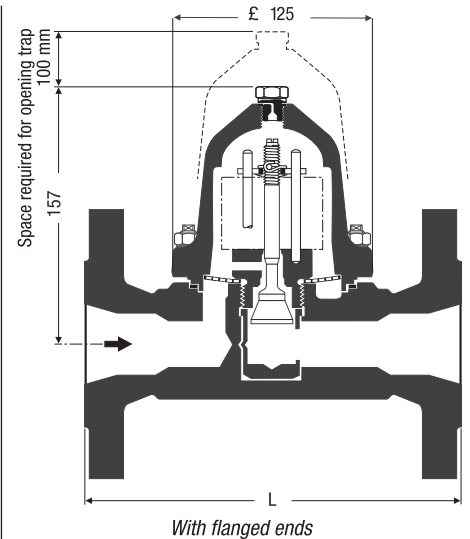

Butt-weld ends to DIN 3239 2-R3, edge form to DIN 2559, code no. 22

DN	d <sub>3</sub>	d <sub>2</sub>	for pipe	L
40 R3	43	49	48.3 x 2.6	20
50 R3	54	61	60.3 x 3.2	20

## Steam Trap BK 27N PN 40 and 63, DN 50 (40) 2" (1½")

### Design

For installation in horizontal and vertical pipes.

### Connections

Flanges: DIN EN 1092-1, Form B1, PN 40  
DIN EN 1092-1, Form B2, PN 63  
ASME Class 400 RF

Socket-weld ends: DIN 3239-R5 / ASME B 16.11  
CI 3000

Butt-weld ends: DIN 3239-2-R3

Other end connections available on request.

### Capacity Chart

The chart shows the maximum capacities for hot and cold condensate discharge at factory setting (steam-tight closure).

#### Curve 1

Discharge of hot water with virtually no banking-up.

#### Curve 2

Cold condensate at a temperature of 20 °C.

### When ordering please state:

Steam pressure, back pressure, quantity of condensate to be discharged, connections, size, position of the trap and details of application.

The following test certificates can be issued on request, at extra cost:

In accordance with EN 10204-2.2 and -3.1.

All inspection requirements have to be stated with the order. After supply of the equipment certification cannot be established. For tests and inspection charges please consult us.

### PED (Pressure Equipment Directive)

The equipment fulfills the requirements of the Pressure Equipment Directive PED 97/23/EC. For application with fluids of group 2. With CE marking (apart from equipment according to section 3.3).

### ATEX (Atmosphère Explosible)

The equipment does not have its own potential source of ignition and is therefore not subject to 94/9/EC. The equipment can be used in potentially explosive areas 0, 1, 2, 20, 21 and 22 (1999/92/EC).

The equipment is not Ex marked.

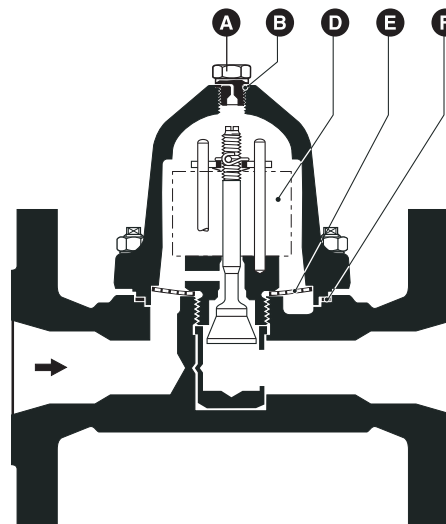
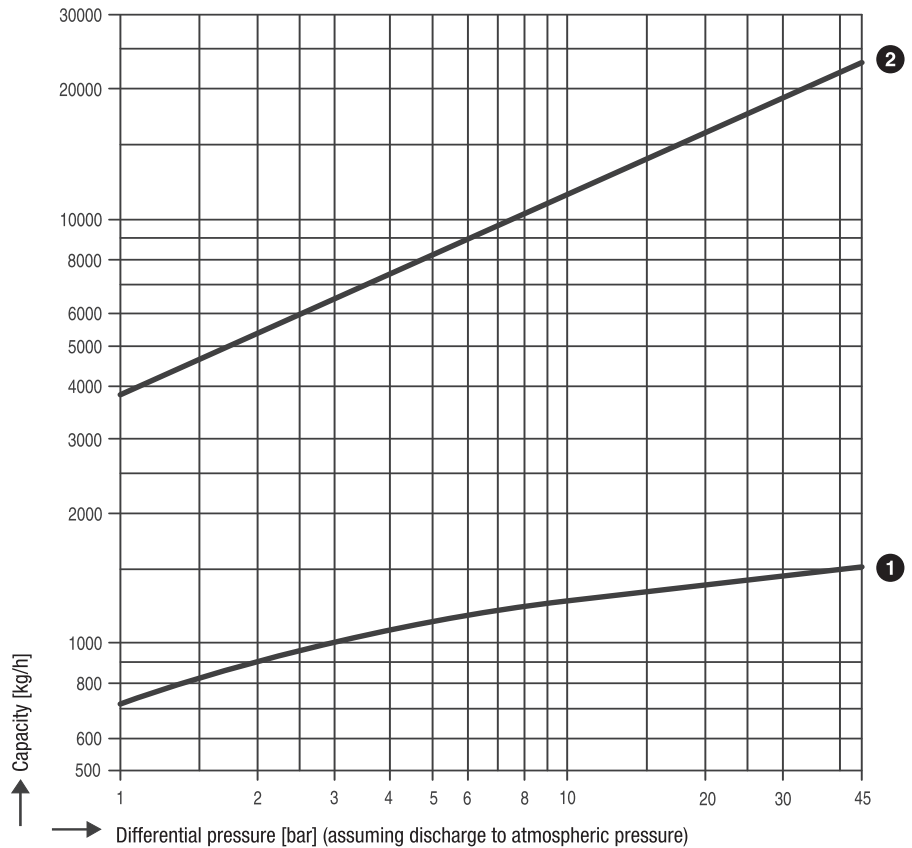

Item	Designation	Stock code no.
ⓓ	Bimetallic regulator BK 27N <sup>3)</sup> complete, including gasket ⓕ	376607
Ⓐ	Plug G ¼ A	096178
Ⓑ	Gasket for plug (A 14 x 8)	000992
ⓕ	Gasket <sup>4)</sup> 92.7 x 102 x 1	376677
Ⓔ	Strainer	097018

<sup>3)</sup> Note: The regulator of the BK 27N does **not** fit into the body of the BK 27!

<sup>4)</sup> 20 pcs. Contact your local dealer for smaller quantities.