

KH112 with handlever

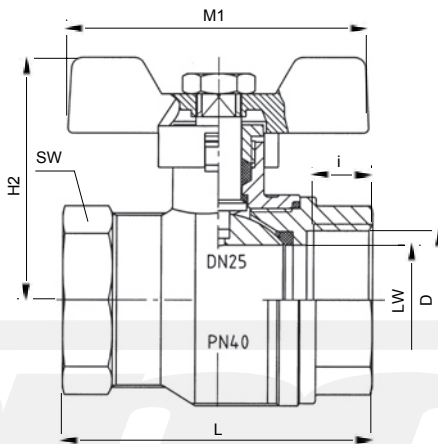

KH112 with T-handle

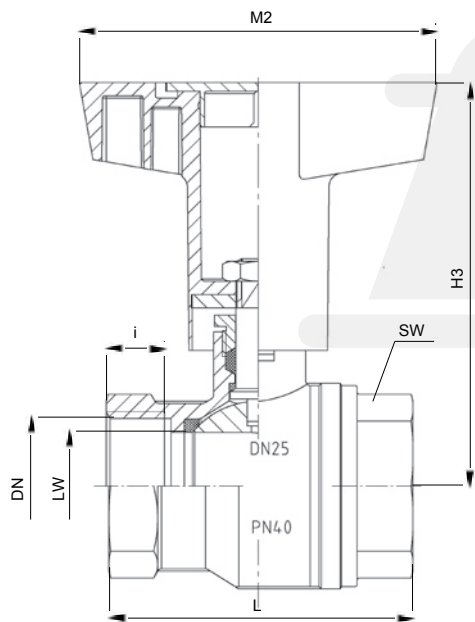

KH112 with ISO-T-handle

Masse / Dimensions [mm]

DN	LW	D ISO-228-1	i	t	L ± 2	g	H1	R	H2	M1	H3	M2	SW	Weight [kg]
6	9	G 1/4	8,5	10	40	1/4-20 UNC	40	82	40	50	74,5	70	20 Hex.	0,128
10	9	G 3/8	8,5	10	40	1/4-20 UNC	40	82	40	50	74,5	70	20 Hex.	0,118
15	14	G 1/4	10	11,5	50	5/16-18 UNC	45	100	44,5	60	74,5	70	25 Oct.	0,184
20	19	G 3/4	11	12,5	60	5/16-18 UNC	49	100	48,5	60	78,5	70	31 Oct.	0,308
25	24	G 1	13	14,5	68	3/8-16 UNC	57	120	53	66	90,5	80	38 Oct.	0,458
32	30	G 1 1/4	14	15,5	80	3/8-16 UNC	62	120	58,4	66	95,5	80	48 Oct.	0,738
40	38	G 1 1/2	16	17,5	94	M12x1,25	80	160			122,5	120	54 Oct.	1,235
50	47	G 2	17	18,5	106	M12x1,25	87	160			130,5	120	66 Oct.	1,970

Werkstoffe / Materials

Bauteil / Part	Material
Gehäuse / Body	1.4408
Kugel / Ball	1.4408
Dichtung / Seal	PTFE
Schaltwelle / Stem	1.4401
Schaltwellendichtung / Stem packing	PTFE

Merkmale / Features

- D**
- Zweiteiliger Kugelhahn
 - Innengewinde nach ISO 228-1
 - Ausblässichere Welle
 - Einstellbare Stopfbuchse
 - Entlastungsbohrung von DN25 - DN50
 - Temperatur: -20°C ... +180°C
 - T-Griff Temperatur: -20°C ... +150°C
 - kurzzeitig bis +170°C
 - Trinkwasserzulassung nach DIN EN 13828 und DVGW W 570

- E**
- Two-Part ball valve
 - Female threads acc. ISO 228-1
 - Blow out proof stem
 - Adjustable stem packing
 - Vent bore from DN25 - DN50
 - Temperature: -20°C ... +180°C
 - T-handle Temperature: -20°C ... +150°C
 - momentary up to +170°C
 - Drinking water registered acc. DIN EN 13828 and DVGW W 570



Druck-Temperaturdiagramm / Pressure-temperature diagram

