

Steam Traps MK 25/2, MK 25/2 S PN 40 / Class 300 DN 40 and 50 (1½ and 2")

Description

Thermostatic steam traps with corrosion resistant thermostatic capsule (membrane regulator). Integral strainer, asbestos-free cover gasket (graphite/CrNi). Installation in any position.

MK 25/2

With four thermostatic capsules "5H2". For condensate flowrates up to e. g. 2800 kg/h at $\Delta p = 5$ bar.

MK 25/2 S

With nine thermostatic capsules "5H2". For condensate flowrates up to e. g. 5000 kg/h at $\Delta p = 5$ bar.

Pressure/Temperature Ratings		PN 40				
Body material	1.0460 (C 22.8) / ASTM A 105					
Nominal sizes (DN)	40, 50					
Connection	Flanged DIN PN 40					
Max. allowable pressure PMA [barg]	40	35	28	21	14.5	
[psig]	580	508	406	305	210	
Inlet temperature TMA [°C]	20	200	300	400	450	
[°F]	68	392	572	752	842	

Pressure/Temperature Ratings		Class 300				
Body material	1.0460 (C 22.8) / ASTM A 105					
Nominal sizes (DN)	40, 50					
Connection	Flanged ASME Class 300					
Max. allowable pressure PMA [barg]	51	43.9	38.9	34.6	20.2	
[psig]	740	637	565	501	294	
Inlet temperature TMA [°C]	20	200	300	400	450	
[°F]	68	392	572	752	842	

Pressure/Temperature Ratings		Class 150				
Body material	1.0460 (C 22.8) / ASTM A 105					
Nominal sizes (DN)	40, 50					
Connection	Flanged ASME Class 150					
Max. allowable pressure PMA [barg]	19.7	14	10.2	6.5	4.6	
[psig]	287	203	149	94.3	66.7	
Inlet temperature TMA [°C]	20	200	300	400	450	
[°F]	68	392	572	752	842	

Max. admissible differential pressure ¹⁾		
Differential pressure ΔPMX [bar]	22	
(inlet pressure minus outlet pressure) [psig]	319	

¹⁾ Observe pressure/temperature ratings!

Materials	DIN		ASTM equivalent
	new designation	old designation	
Body		C 22.8 (1.0460)	A 105
Cover MK 25/2		C 22.8 (1.0460)	A 105
Cover MK 25/2 S	GP240GH	GS-C 25 (1.0619)	A 216 Gr WCB
Bolts		42CrMo4 (1.7225)	A 193 B 7
Body gasket	Graphite		
Thermostatic capsule	Hastelloy® / Stainless steel		
Other internals	Stainless steel		

Dimensions and Weights	Flanged DIN		Flanged ASME		Screwed sockets Socket-weld ends		Butt-weld ends		
	[mm]	[inch]	[mm]	[inch]	[mm]	[inch]	[mm]	[inch]	
Nominal size	40	50	40	50	40	50	40	50	
	1½	2	1½	2	1½	2	1½	2	
Face-to-face dimensions L	230	230	230	230	130	210	250	240	
Approx. weight [kg]	MK 25/2	11	12.5	11	12.5	6.3	7.7	6.8	7.5
	MK 25/2 S	11.5	13	11.5	13	6.8	8.5	7.3	8

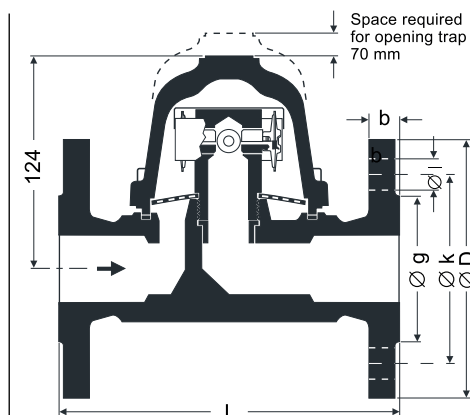

MK 25/2, DN 40 and 50 mm (1½ and 2")

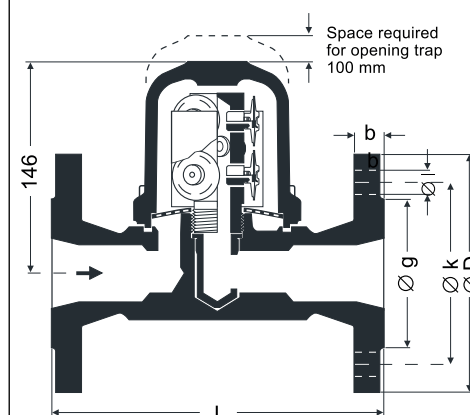

MK 25/2 S, DN 40 and 50 mm (1½ and 2")

Connection

Flange: DIN 2635, form C, PN 40.
ASME B 16.5, 150 RF and 300 RF.
Socket-weld ends
Butt-weld ends
Screwed to BSP and NPT

Capacity Chart

The chart shows the maximum capacities for hot and cold condensate.

MK 25/2

Curve 1:
Condensate temperature 10 K (degC) below saturation temperature.

Curve 2:
Cold condensate at a temperature of 20 °C (start-up capacity).

MK 25/2 S

Curve 3:
Condensate temperature 10 K (degC) below saturation temperature

Curve 4:
Cold condensate at a temperature of 20 °C (start-up capacity)

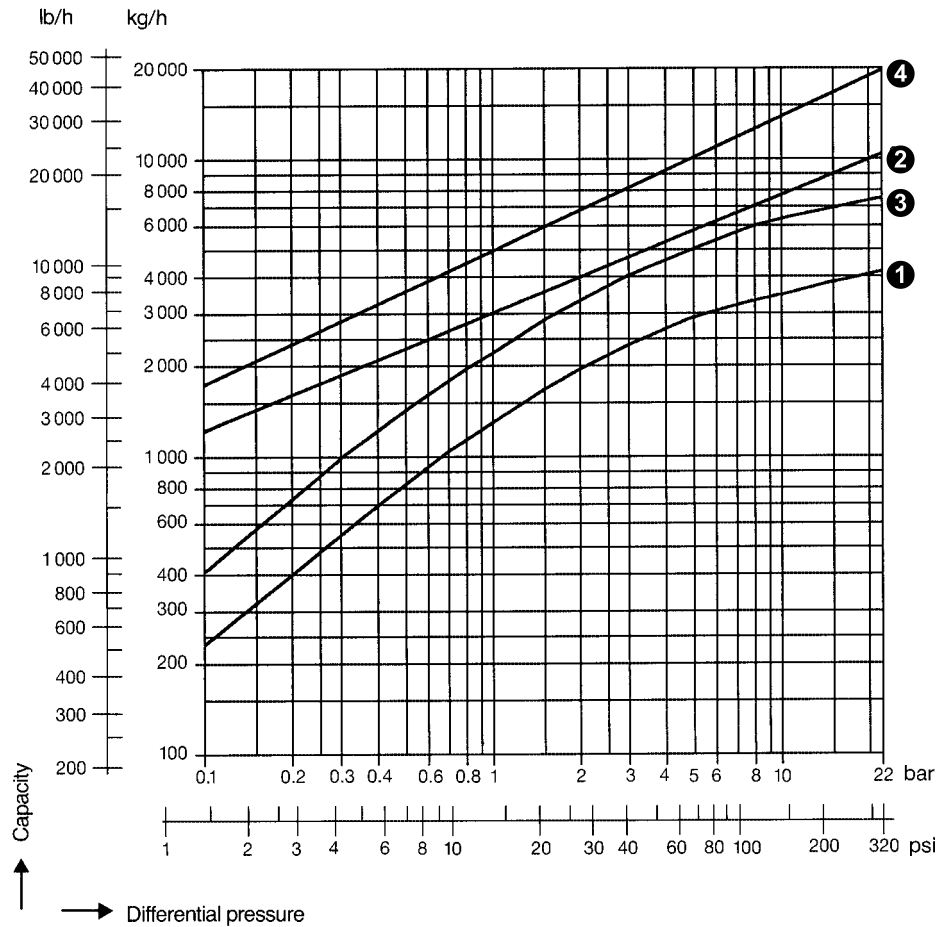

When ordering please state:

Steam pressure, back pressure, quantity of condensate to be discharged, type, size, connections, mounting position of the trap and details of application.

The following test certificates can be issued on request, at extra cost:

In accordance with DIN EN 10204/2.2. and -3.1B. All inspection requirements have to be stated with the order. After supply of the equipment certification cannot be established. For tests and inspection charges please consult us.

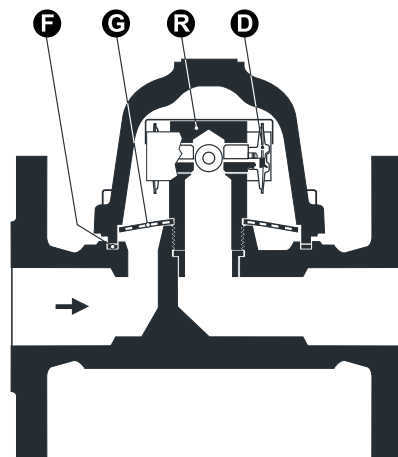

These products comply with the requirements of the EC Pressure Equipment Directive (PED) 97/23. DN 40, 50 with CE marking.

Supply in accordance with our general terms of business.

Item	Designation	Stock code	
		MK 25/2	MK 25/2 S
R	Regulator with cover gasket	098770	098774
D	Capsule 5H2 1)	376174	376174
F	Gasket ²⁾ 92.7 x 102 x 1	087095	087095
G	Strainer, cover gasket	375698	375698

1) Packed 10 per box. Contact your local dealer for smaller quantities.

2) Packed 20 per box. Contact your local dealer for smaller quantities.