

UNA 41 h

## Ball Float Steam Trap

### UNA 41 PN 16/Class 150 DN 15, 20, 25

#### Description

Float traps type UNA 41 are designed for removing condensate from steam or compressed air.

Equipment fitted with control unit SIMPLEX is operated and controlled by the float with rolling ball. Equipment with this control unit is particularly suitable for cold condensates or superheated steam.

Equipment with control unit DUPLEX may also be used for air venting the installation. This type of control unit is particularly suitable for saturated steam systems. The control unit DUPLEX consists of a float operated rolling ball valve and a temperature dependent air-venting facility. Do not expose the membrane regulator capsule of the DUPLEX control unit to superheat conditions above 5 K.

The optional hand-vent valve allows you to air vent the equipment manually.

The equipment must only be used within the allowable pressure and temperature limits and only if the chemical and corrosive influences on the equipment are taken into account.

#### Function

The control unit opens the orifice as a function of the liquid level. A rising level results in a proportional opening of the equipment. The max. discharge capacity depends on the orifice size when the ball is completely lifted off its seat and the orifice is fully open.

#### Optional extras

Hand-vent valve allows manual air-venting of the pipeline

The different equipment versions allow you to adjust the flow direction of the equipment to the flow pattern of your installation. The flow arrow must correspond to the direction of the fluid flow. The following positions of installation are possible:

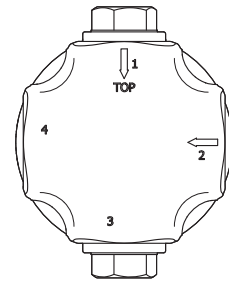

Design "h" for installation in horizontal pipework

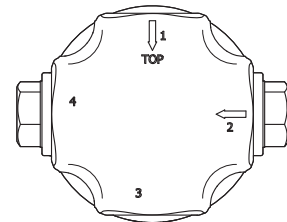

Design "v" for installation in vertical pipework with downward flow

#### End connections

Flange EN 1092-1 B1 PN 1016 (DN 15, 20)

Flange ASME B 16.5 Class 150 RF (DN 15, 20)

Screwed sockets G: ISO 228/1

Screwed sockets NPT: ASME B 16.11

Socket-weld ends to DIN EN 12760

Socket-weld ends ASME B 16.11 Class 3000

Butt-weld ends via transition pieces to EN 12627, welded joint geometry ISO 9692-1 code number 1.3 (30° chamfer)

Butt-weld ends via transition pieces

ASME B 16.25 ASME B 36.10

#### Materials

Component part	EN	ASTM
Body	1.0460	A105
Cover	1.0619	A216-WCB
Membrane regulator capsule	Hastelloy / stainless steel	
Other components, gasket	Stainless steel	

## Dimensions and weights

### Equipment with flanges EN 1092-1 PN 16

Nominal size		DN 15 (½")	DN 20 (¾")
L	[mm (in)]	150 (5.9)	
H	[mm (in)]	102 <sup>1)</sup> (4,0)	
X	[mm (in)]	18 (0.7)	
B	[mm (in)]	164 (6.5)	
Weight	[kg (lb)]	6.7 (14.7)	7.3 (16.1)

<sup>1)</sup> If equipped with hand-vent valve add 46 mm (1.8 in).  
To operate the hand-vent valve a service space of 100 mm (4 in) is required.

### Equipment with flange ASME CL150

Nominal size		DN 15 (½")	DN 20 (¾")
L	[mm (in)]	150 (5.9)	
H	[mm (in)]	102 <sup>1)</sup> (4,0)	
X	[mm (in)]	18 (0.7)	
B	[mm (in)]	164 (6.5)	
Weight	[kg (lb)]	6.2 (13.7)	6.6 (14.5)

<sup>1)</sup> If equipped with hand-vent valve add 46 mm (1.8 in).  
To operate the hand-vent valve a service space of 100 mm (4 in) is required.

### Equipment with socket-weld ends EN and ASME Equipment with screwed sockets G and NPT

Nominal size		DN 15 (½")	DN 20 (¾")	DN 25 (1")
L	[mm (in)]	95 (3.7)		
H	[mm (in)]	102 <sup>1)</sup> (4,0)		
X	[mm (in)]	18 (0.7)		
B	[mm (in)]	142 (5.6)		
Weight	[kg (lb)]	4.3 (9.5)	4.2 (9.3)	

<sup>1)</sup> If equipped with hand-vent valve add 46 mm (1.8 in).  
To operate the hand-vent valve a service space of 100 mm (4 in) is required.

### Equipment with butt-weld ends via transition pieces to EN and ASME

Nominal size		DN 15 (½")	DN 20 (¾")	DN 25 (1")
L	[mm (in)]	200 (7.9)		
H	[mm (in)]	102 <sup>1)</sup> (4,0)		
X	[mm (in)]	18 (0.7)		
B	[mm (in)]	142 (5.6)		
Weight	[kg (lb)]	4.7 (10.4)	4.8 (10.6)	

<sup>1)</sup> If equipped with hand-vent valve add 46 mm (1.8 in).  
To operate the hand-vent valve a service space of 100 mm (4 in) is required.

## Dimensions and weights

The drawing shows equipment with flanged ends for horizontal installation.

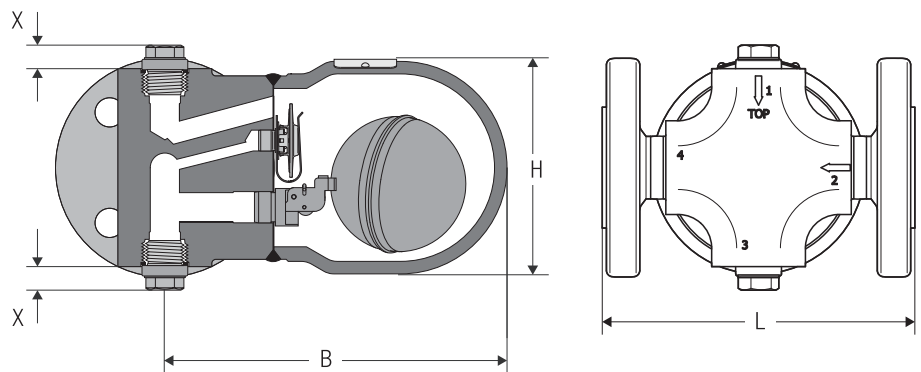

The drawing shows equipment with screwed sockets or socket-weld ends for horizontal installation.

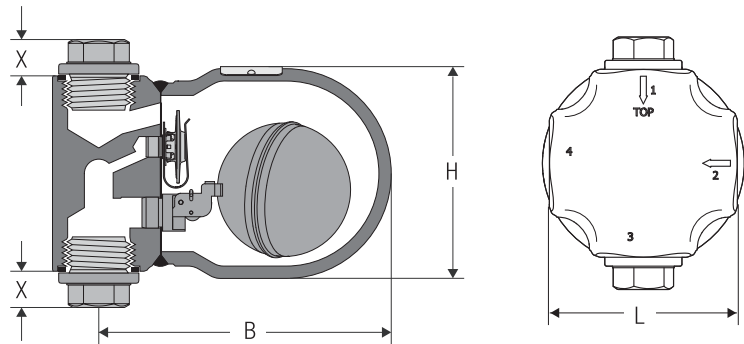

## Pressure & temperature ratings

The values indicated in the following tables apply to standard equipment.

Note that the type of end connection used may restrict the use of the equipment to below the pressure/temperature limits quoted. All equipment specific values are indicated on the nameplate.

### Limiting conditions for UNA 41, flange PN 16, screwed sockets G

Pressure <sup>1)</sup> p	[barg]	16	14.8	14.0	13.3	11.0	5.2
Temperature <sup>1)</sup> T	[°C]	-10/20	100	150	200	300	450
Max. admissible differential pressure ΔPMX	[barg]	5 (orifice 5), 14 (orifice 14)					
	[psi]	73 (orifice 5), 203 (orifice 14)					
Admissible service temperature	Control unit DUPLEX: Saturated steam temperature plus 5 K						
Pressure <sup>1)</sup> p	[psig]	232	215	203	193	160	75
Temperature <sup>1)</sup> T	[°F]	14/68	212	302	392	572	842

<sup>1)</sup> Limit values for body/cover to EN 1029-1

### Limiting conditions for UNA 41 flange Class 150, screwed socket NPT, socket-weld end, butt-weld end via transition piece

Pressure <sup>1)</sup> p	[barg]	19.6	17.7	13.8	10.2	8.4	5.5
Temperature <sup>1)</sup> T	[°C]	-29/20	100	200	300	350	425
Max. admissible differential pressure ΔPMX	[barg]	5 (orifice 5), 14 (orifice 14)					
	[psi]	73 (orifice 5), 203 (orifice 14)					
Admissible service temperature	Control unit DUPLEX: Saturated steam temperature plus 5 K						
Pressure <sup>1)</sup> p	[psig]	285	260	200	140	125	80
Temperature <sup>1)</sup> T	[°F]	20/100	200	400	600	650	800

<sup>1)</sup> Limit values for body/cover to ASME B 16.5

## Ball Float Steam Trap

### UNA 41

### PN 16/Class 150

### DN 15, 20, 25

#### PED (Pressure Equipment Directive)

The equipment fulfils the requirements of the Pressure Equipment Directive PED 97/23/EC and can be used for the following fluids:

Fluids of group 2

The equipment is excluded from the scope of the PED according to section 3.3 and must not bear a CE marking.

#### ATEX (Atmosphère Explosible)

The equipment does not have its own potential source of ignition and is therefore not subject to the ATEX Directive 94/9/EC.

The equipment is not Ex marked.

Please observe the following notes if the equipment is to be used in explosion-risk areas:

The equipment can be used in zones (surrounding atmosphere acc. to Directive 1999/92/EC) 0, 1, 2, 20, 21 and 22 (ATEX Directive 94/9/EC).

Make sure that the operating fluid does not generate a surface temperature that exceeds the limit specified for the place of installation.

If the equipment is electrically insulated when installed between pipe end connections, appropriate measures must be taken to discharge any static electricity.

#### Inspection & Certification

Documentation regarding material tests and in-house examination with test report EN10204 available. All inspection requirements have to be stated with the enquiry or order. After supply of the equipment certification cannot be established. Charges and extent of the above mentioned test certificates as well as the different tests confirmed therein are listed in our Price List "Test and Inspection Charges for Standard Equipment". For other tests and inspections than those listed above, please consult us.

#### Capacity Chart

The chart shows the maximum capacities for hot condensate for the respective orifice.

The capacities are dependent on the differential pressure (working pressure). The differential pressure is the difference between inlet and outlet pressure and depends among other things on the run of the condensate line. If the condensate downstream of the trap is lifted, the differential pressure is reduced by 1 bar for 7 m lift.

The maximum admissible differential pressure is dependent on the cross-sectional area of the orifice and the density of the liquid.

This curve indicates the max. capacity of hot condensate that the steam trap UNA 41 can discharge with virtually no banking up.

The max. capacity of cold water that the steam trap with control unit SIMPLEX or DUPLEX can discharge is: Capacity multiplied by factor F.

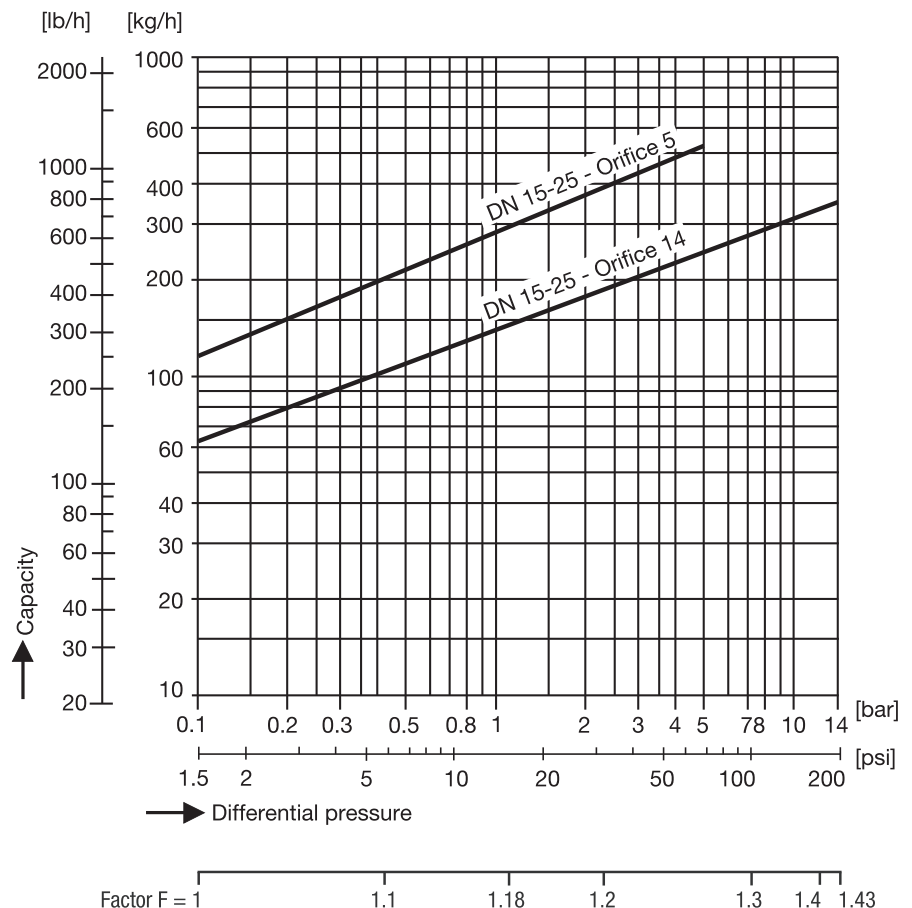

#### Operating data

Equipment with control unit DUPLEX: The max. service temperature corresponds to the saturated steam temperature +5 K.

The max. differential pressure  $\Delta$  PMX of the equipment depends on the type of orifice (O) used.

Orifice	$\Delta$ PMX [bar]
5	5
14	14

#### Spare Parts

No spare parts are available for the equipment.

Replace a defective device with a new one.

#### Accessories

**Hand-vent valve** with socket spanner for equipment with control unit SIMPLEX and flanged ends, socket-weld ends or butt-weld ends:

G 3/8" Stock code # 229197

**Hand-vent valve** with socket spanner and adapter for equipment with control unit SIMPLEX and screwed sockets:

Stock code #	with gasket	without gasket
Connection G 1/2"	229191	
Connection G 3/4"	229192	
Connection G 1"	229193	
Connection NPT 1/2"		229194
Connection NPT 3/4"		229195
Connection NPT 1"		229196

#### Gaskets

G 1/2"	Stock code # 388204
G 3/4"	Stock code # 388200
G 1"	Stock code # 388201