

**BIDIRECTIONAL TIGHTNESS**

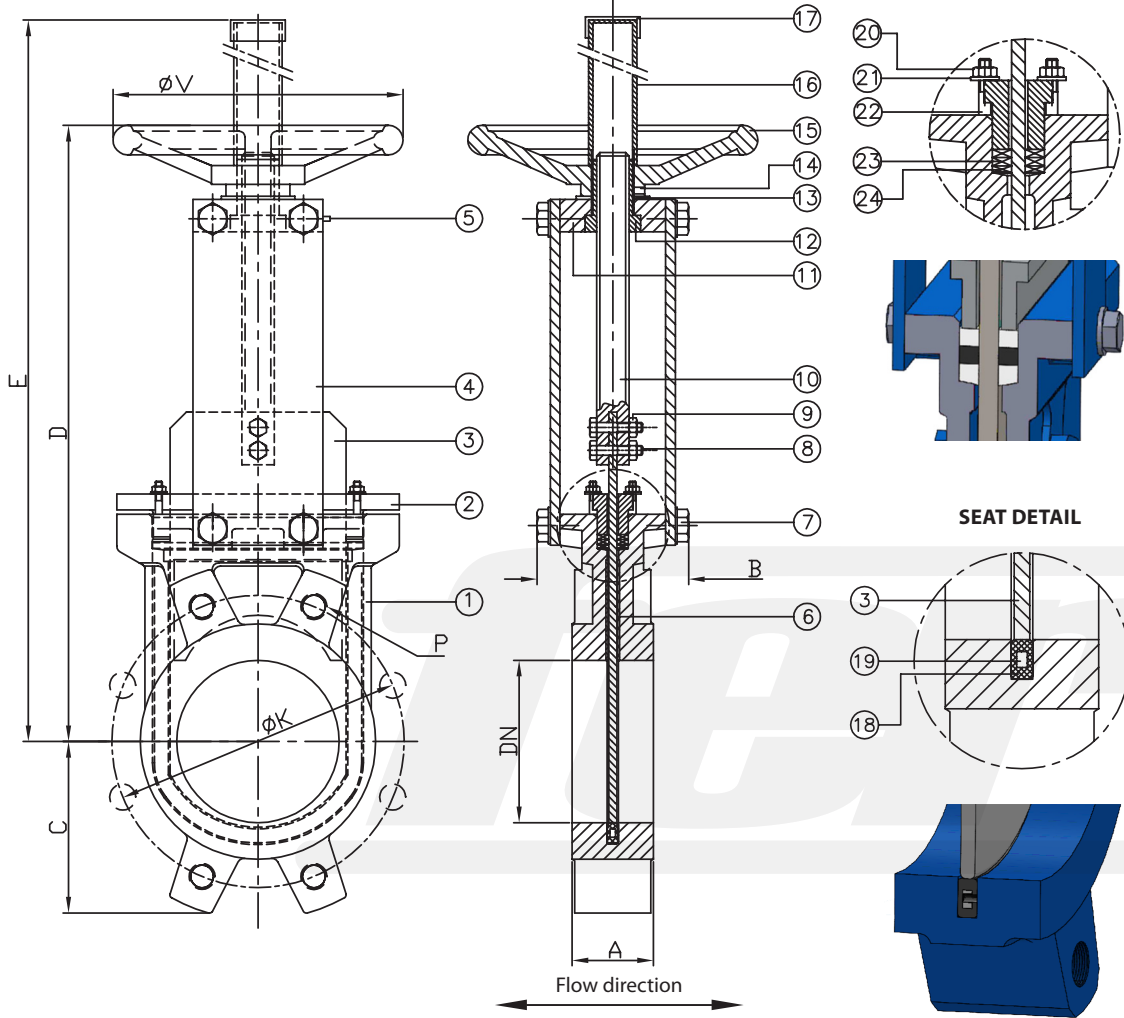

**PACKING DETAIL**

Dimensions\*

DN	INCH	A	B	C	D	E	ØV	ØK PN10	P No. holes	P PN10
50	2"	40	90	65	285	399	200	125	4	M16
65	2 1/2"	40	90	70	310	426	200	145	4	M16
80	3"	50	90	92	336	451	200	160	8	M16
100	4"	50	90	107	382	497	200	180	8	M16
125	5"	50	100	120	430	577	250	210	8	M16
150	6"	60	100	130	480	627	250	240	8	M20
200	8"	60	120	158	595	801	310	295	8	M20
250	10"	70	120	200	697	953	310	350	12	M20

Materials\*

Execution in:	Cast iron
1 <b>Body</b>	GG25
2 <b>Gasket clamp</b>	Aluminium
3 <b>Gate</b>	1.4306/SS304L
4 <b>Support plate</b>	Steel
5 <b>Oiling nipple</b>	Standard
6 <b>Internal guides</b>	Cestilene HD1000
7 <b>Bolt</b>	A2
8 <b>Union studs</b>	A2
9 <b>Union nuts</b>	A2
10 <b>Stem</b>	1.4305/SS303
11 <b>Support bridge</b>	Steel
12 <b>Stem drive nut</b>	Brass
13 <b>Washer</b>	Brass
14 <b>Stop screw</b>	A2
15 <b>Handwheel</b>	GG25
16 <b>Tube</b>	Steel
17 <b>Cover</b>	Plastic
18 <b>Seat</b>	EPDM / NBR / Viton
19 <b>Seat reinforcement</b>	Steel
20 <b>Studs</b>	A2
21 <b>Washer</b>	A2
22 <b>Nut</b>	A2
23 <b>Packing o-ring</b>	EPDM / NBR / Viton
24 <b>Packing</b>	Synt. + PTFE

Maximum working pressure recommended  
DN50 - DN250: 10 bar

Standard test pressure  
DN50 - DN250: 6 bar

Colour\*  
 RAL 5015

Flanges drilled according to  
EN 1092-2 and DIN 2501: ISO PN10 or ANSI 150

- U-profile perimeter resilient seat
- Internal gate guides with integrated scraper effect
- Full bore 100%

(for further informations please visit our download section on our website)

\*Other dimensions / materials / colours on request.