

Technical Manual

Register: 9
Page: 1
Date: 04.1995
Revision: 06.2020

Your distribution partner:

 Bindersweg 31 • D-41489 Neuss • Tel.: +49 2131 / 15 39 28-0 • Fax: +49 2131 / 15 39 28-99 • info@atmac.eu • www.atmac.eu

Register 9 CONTENTS - ARV/SG

Contents	Page
<i>Technical Data ARV/SG-DIN</i>	2
<i>Technical Data ARV/SG-ANSI</i>	3
<i>Material Specification ARV/SG</i>	4
<i>Dimensions ARV/SG-DIN</i>	5
<i>Dimensions ARV/SG-ANSI</i>	6
<i>Spare Parts ARV/SG</i>	7
<i>Assembly Instructions ARV/SG</i>	8
<i>Disassembly Instructions ARV/SG</i>	8
<i>ARV/SG - Recommended Tightening Torques</i>	9
<i>ARV/SG - Kv and Cv - Data</i>	9



Technical Manual

Technical Data ARV/SG

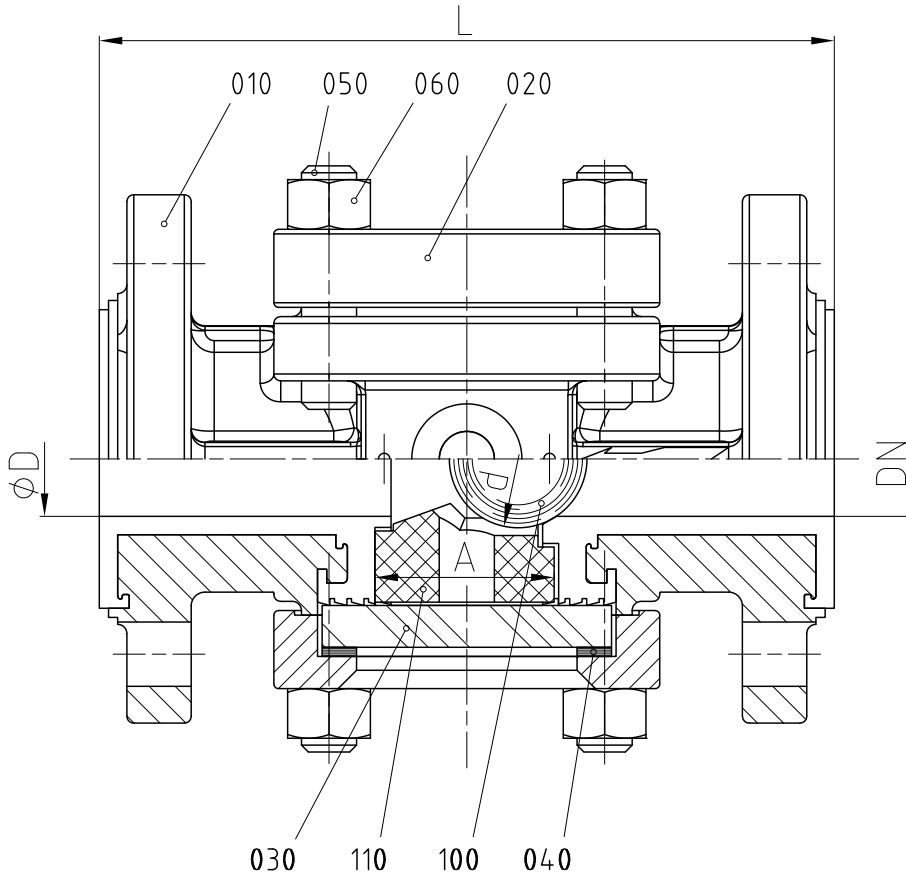

Face-to-Face Dimensions DIN EN 558 (Basic series 1)
 Flange Connections DIN EN 1092-2 PN 16

DN / DIN		L	ØD	Ød	A	weight	
025	mm	160	25	30	33	kg	5,2
	inch	6,3	0,98	1,18	1,3	lbs	11,5
040	mm	200	32	40	45	kg	11,0
	inch	7,87	1,26	1,57	1,77	lbs	24,1
050	mm	230	40	50	65	kg	12,2
	inch	9,06	1,57	1,97	2,56	lbs	26,9
080	mm	310	65	80	80	kg	21,2
	inch	12,2	2,56	3,15	3,15	lbs	46,7
100	mm	350	80	100	100	kg	28,6
	inch	13,78	3,15	3,94	3,94	lbs	62,9
150	mm	480	150	145	162,5	kg	64,0
	inch	18,9	5,91	5,71	6,4	lbs	141,1

Technical Manual

Technical Data ARV/SG

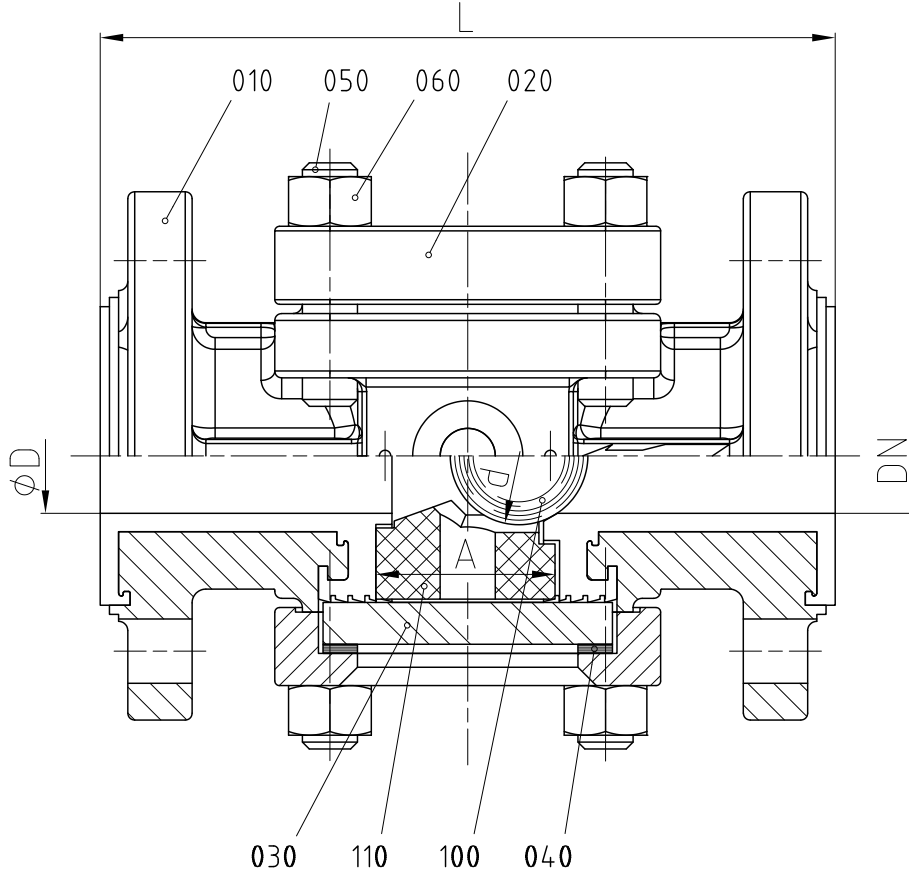

Flange Connections ANSI B 16.5 Cass 150,
 Min. Flange thickness acc.
 to ASME B 16.5 Cass 150,
 Table 9 (Flanged Fittings)

DN / ANSI	L	ØD	Ød	A	weight
1"	inch 6	0,98	1,18	1,3	lbs 10,4
	mm 152,4	25	30	33	kg 4,7
1½"	inch 7	1,26	1,57	1,77	lbs 19,8
	mm 178	32	40	45	kg 9,0
2"	inch 8	1,57	1,97	2,56	lbs 23,8
	mm 203	40	50	65	kg 10,8
3"	inch 9,5	2,56	3,15	3,15	lbs 40,1
	mm 241	65	80	80	kg 18,2
4"	inch 11,5	3,15	3,94	3,94	lbs 62,0
	mm 292	80	100	100	kg 28,2

Technical Manual

Material specification ARV/SG

No.	Designation	Pieces	Material	Material-No. / DIN	ASTM / AISI
010	body	1	ductile iron / PFA	EN-JS1049 (GGG-40.3) / DIN EN 1563	A 395
		1	ductile iron / PFA conductive	EN-JS1049 (GGG-40.3) / DIN EN 1563	A 395
020	flange	1	ductile iron / PFA	EN-JS1049 (GGG-40.3) / DIN EN 1563	A 395
		1	ductile iron / PFA conductive	EN-JS1049 (GGG-40.3) / DIN EN 1563	A 395
030	glass	2	borosilicate-glass	DIN 7080	
040	flat gasket	2	UNITEC 300 green	DIN 3535-6	
050	stud bolt	1 set	stainless steel	1.4301-K70 / DIN EN 10088-3	A 193 B8
060	hexagon nut	1 set	stainless steel	1.4301-K70 / DIN EN 10088-3	A 194 8
100	ball	1	PTFE-solid ball		
		1	PTFE-solid ball conductive		
110	ball guide	2	PTFE	pure-PTFE	

Valves with conductive lining only contain components with conductive materials

Technical Manual

Dimensions ARV/SG

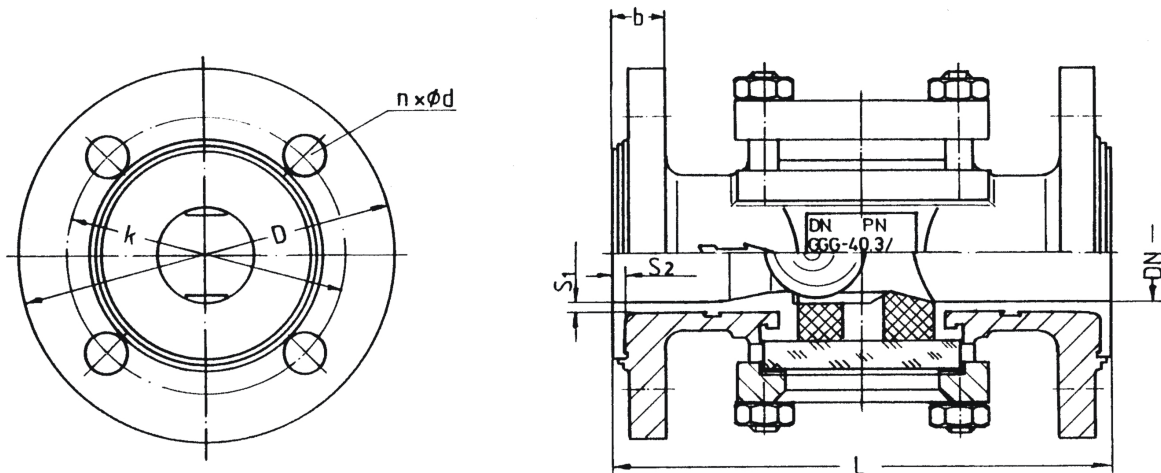

DN / DIN		L	b	D	k	nxØd	S1	S2
025	mm	160	20	115	85	4x14	4	4
	inch	6,3	0,79	4,53	3,35	4x0,55	0,16	0,16
040	mm	200	21,5	150	110	4x18	4	4
	inch	7,87	0,85	5,91	4,33	4x0,71	0,16	0,16
050	mm	230	23	165	125	4x18	4	4
	inch	9,06	0,91	6,5	4,92	4x0,71	0,16	0,16
080	mm	310	25	200	160	4x18	5	4
	inch	12,2	0,98	7,87	6,3	4x0,71	0,2	0,16
100	mm	350	25	220	180	4x18	5	4
	inch	13,78	0,98	8,66	7,09	4x0,71	0,2	0,16
150	mm	480	29	285	240	8x19	5,5	4
	inch	18,9	1,14	11,22	9,45	8x0,75	0,22	0,16

Technical Manual

Dimensions ARV2/SG

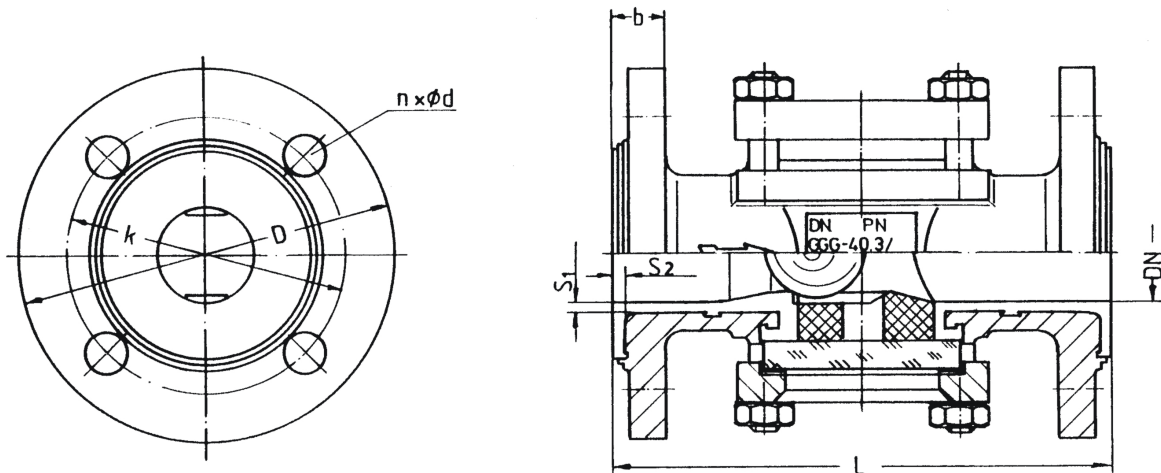

DN / ANSI		L	b	D	k	nxØd	S1	S2
1"	inch	6	0,63	4,25	3,12	4x0,63	0,16	0,16
	mm	152,4	16	107,9	79,2	4x16	4	4
1½"	inch	7	0,85	5	3,88	4x0,63	0,16	0,16
	mm	178	21,5	127	98,5	4x16	4	4
2"	inch	8	0,87	6	4,74	4x0,75	0,16	0,16
	mm	203	22	152,4	120,5	4x19	4	4
3"	inch	9,5	0,94	7,5	6	4x0,75	0,2	0,16
	mm	241	24	190,5	152,5	4x19	5	4
4"	inch	11,5	1,08	9	7,5	8x0,75	0,2	0,16
	mm	292	27,5	228,6	190,5	8x19	5	4

Spare Parts (item n°) - ARV/SG

DIN	ANSI	Ball PTFE
025	1"	0001451
040	1½"	0001457
050	2"	0001452
080	3"	0001458
100	4"	0001454
150	---	0009495

DIN	ANSI	Glass Set	Flat gaskets Set
025	1"	0009537	0009543
040	1½"	0009538	0009544
050	2"	0009539	0009545
080	3"	0009540	0009546
100	4"	0009541	0009547
150	---	0009542	0009548

ASSEMBLY INSTRUCTIONS ARV/SG

The general installation and maintenance instructions must be observed.

1. When assembling ARV/SG special care must be taken. In particular, the sealing surface has to be absolutely clean and free from any damage.
2. Screw in stud bolts **(050)**.
3. Press in first ball guide **(110)**.
4. Insert first glass **(030)**.
5. Insert first gasket **(040)**.
6. Put on first flange **(020)**.
7. Assemble hexagon nuts **(060)**.
8. Insert ball **(100)**.
9. Press in second ball guide **(110)**.
10. Insert second glass **(030)**.
11. Insert second gasket **(040)**.
12. Put on second flange **(020)**.
13. Tighten hexagon nuts **(060)** by criss-cross method acc. to recommended torques.

DISASSEMBLY INSTRUCTIONS ARV/SG

For all jobs which are to be carried out on an installed valve, the works safety requirements and the general installation and maintenance instructions for fluorocarbon resin lined atomac valves must be observed.

1. Prior to disassembly, the valve must be drained of all line media, acc. to the abovementioned instructions.
2. Remove hexagon nuts **(060)**.
3. Remove parts as follows:
 - a. flange **(020)**
 - b. gasket **(040)**
 - c. glass **(030)**
 - d. ball guide **(110)**
 - e. ball **(100)**
 - f. ball guide **(110)**
4. Remove stud bolts **(050)**.

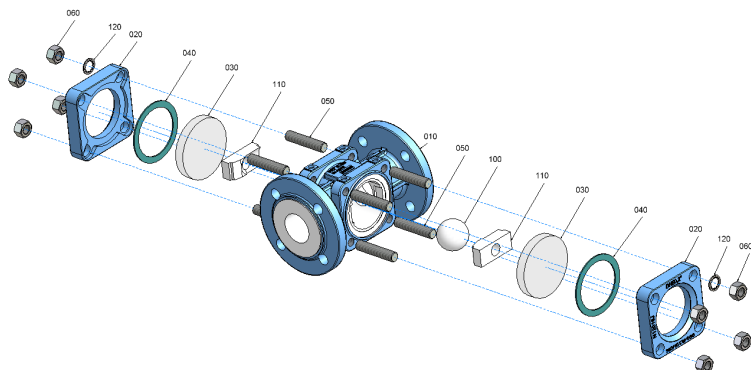

Technical Manual

ARV/SG- recommended tightening torques*

DN	tie rods		connection flange	
	Nm	lbf · in	Nm	lbf · in
025	13,7	121	25	221
1"	14,2	126	15	133
040	19	168	50	442
1½"	20	177	26	230
050	38,5	341	65	575
2"	39	345	60	531
080	52	460	55	487
3"	52,5	465	100	885
100	44,5	394	64	566
4"	45	398	76	673
150	61,6	545	123,6	1094

* max. value

When bolting together dissimilar materials, always tighten to the lowest recommended torque of the components in the joint. Using higher torques may cause excessive deformation of the „softer“ material in the joint

ARV/SG - K_v Data and C_v Data (DIN EN 60534-2-3)

DIN	ANSI	K _v m³/h	C _v gal/min
025	1"	12,5	14,5
040	1 ½"	25,9	30,1
050	2"	48,1	55,9
080	3"	95,4	110,9
100	4"	159,3	185,2
150	---	At time not available	