

AK130

Split Wafer DN32-200 | PN10-16-ANSI150

VALVE WITH BARE SHAFT

Model: 20WP4040T PTFE

Date: 11-07-2018

Revision: 0

Page: 1/2

- ▶ **Body** Ductile Iron
EN 1563 - GJS500-7
- ▶ **Shaft + Disc** Stainless Steel
ASTM A182 F316 + PTFE
coated
- ▶ **Seat** PTFE
- ▶ **Temperature** -25°C up to +220°C
- ▶ **Tolerances** ISO 2768-M
- ▶ **Face to Face** EN 558 Series 20
ISO 5752 Series 20
API 609 Table 1
BS 5155 Series 4
- ▶ **Pressure test according to standards** API 598, ISO 5208:
Body: 1.5×PN
Seat: 1.1×PN
- ▶ **Mounting between flanges** ISO 7005 - 1, 2 & 3 PN10-16
ANSI B16.5 CL. 150#
JIS B2210 - 10K
AS2129 TABLE E
- ▶ **Tightness test** ISO 5208, Rate A
API 598

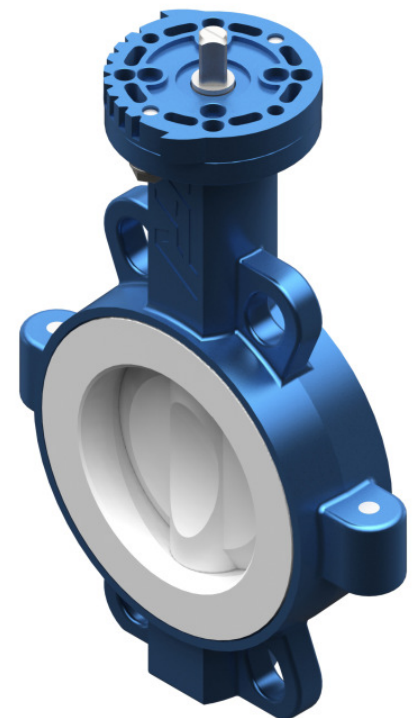
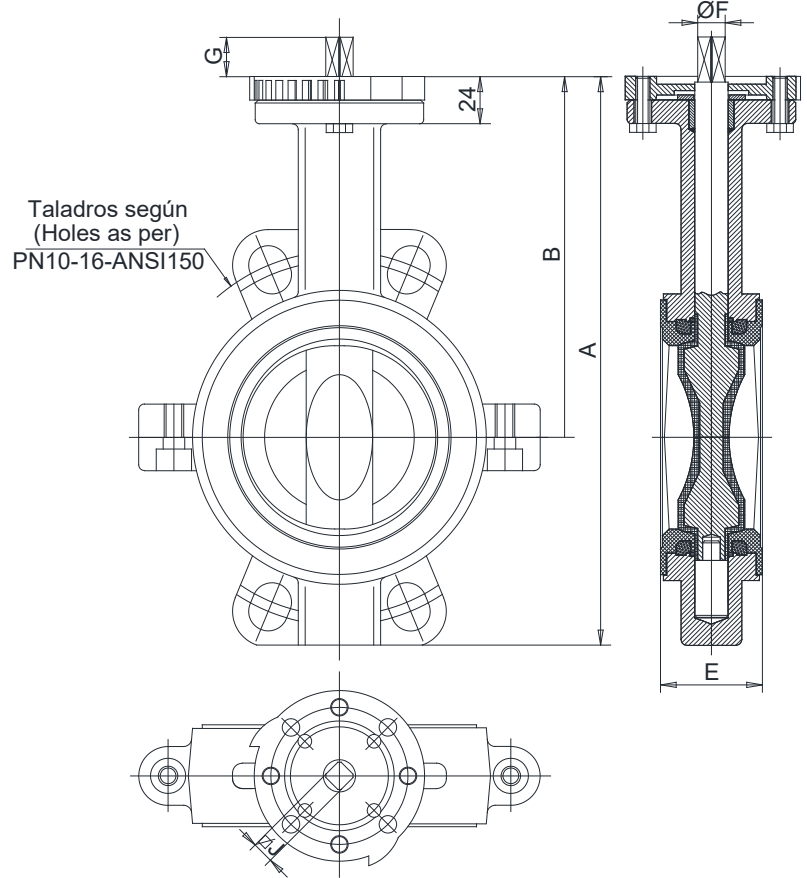

DN		A	B	E	F	G	J	ISO 5211	Weight Kg
mm	inch								
40	1½"	205	140	33	9.8	14	8	F05-07	2.5
50	2"	226	156	43	9.8	14	8	F05-07	4
65	2½"	242	161	46	12	16	9	F05-07	5
80	3"	262	167	46	14	16	11	F05-07	5.5
100	4"	290	184	52	14	20	11	F07	7
125	5"	326	207	56	18	20	14	F07	9.5
150	6"	348	215	56	18	20	14	F07	10.5
200	8"	438	257	60	22	24	17	F07	17.5

Your distribution partner:



Blindeisenweg 31 • D-41468 Neuss • Tel.: +49 2131 / 15 39 28-0 • Fax: +49 2131 / 15 39 28-99 • info@fergo.eu • www.fergo.eu

AK130

Split Wafer DN250-300 | PN10-16-ANSI150

VALVE WITH BARE SHAFT
Model: 20WPD1D1T PTFE

Date: 11-07-2018

Revision: 0

Page: 2/2

- ▶ **Body** Ductile Iron
EN 1563 - GJS500-7
- ▶ **Shaft + Disc** Stainless Steel
ASTM A890 Grade 1B +
PTFE coated
- ▶ **Seat** PTFE
- ▶ **Temperature** -25°C up to +220°C
- ▶ **Tolerances** ISO 2768-M
- ▶ **Face to Face** EN 558 Series 20
ISO 5752 Series 20
API 609 Table 1
BS 5155 Series 4
- ▶ **Pressure test according to standards** API 598, ISO 5208:
Body: 1.5×PN
Seat: 1.1×PN
- ▶ **Mounting between flanges** ISO 7005 - 1, 2 & 3 PN10-16
ANSI B16.5 CL. 150#
JIS B2210 - 10K
AS2129 TABLE E
- ▶ **Tightness test** ISO 5208, Rate A
API 598

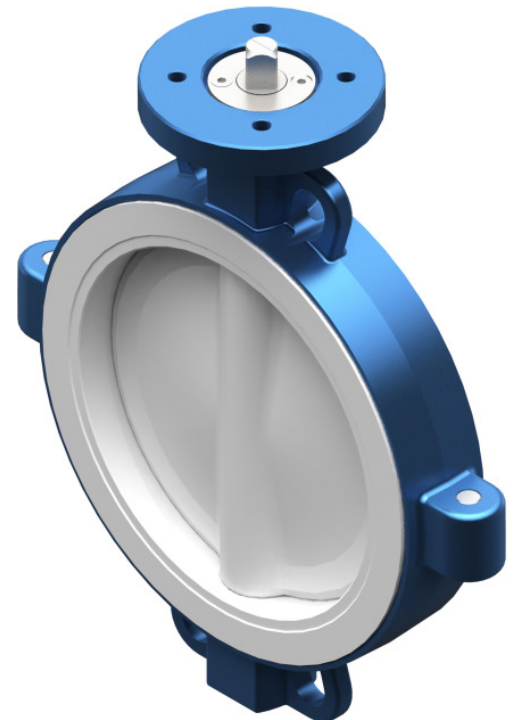
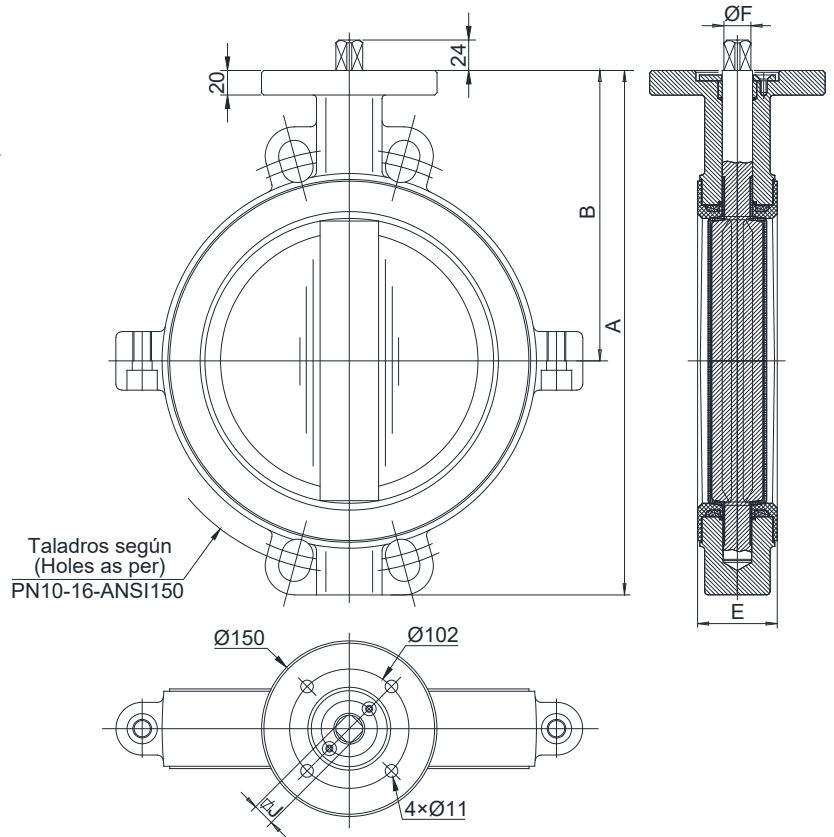

DN		A	B	E	F	J	Weight Kg
mm	inch						
250	10"	448	248	68	25	19	30,5
300	12"	524	280	78	28	22	42

Your distribution partner:



Blindeisenweg 31 • D-41468 Neuss • Tel.: +49 2131 / 15 39 28-0 • Fax: +49 2131 / 15 39 28-99 • info@fergo.eu • www.fergo.eu